



**MONTAGEANLEITUNG**  
**COUCHTISCH TYPE 3612 / 3610**  
**GLASWINKELBORD TYPE 3782 / 3752**

COFFEE TABLE / RIGHT-ANGLED GLASS SHELF  
TABLE BASSE / ABLETTE EN L EN VERRE  
SALONTAFEL / GLAZEN BOEKENPLANK MET WANDPANEEL

**now!** no.14  
by hülsta

**MONTAGEANLEITUNG · ASSEMBLY INSTRUCTION · NOTICE DE MONTAGE · MONTAGEHANDLEIDING**

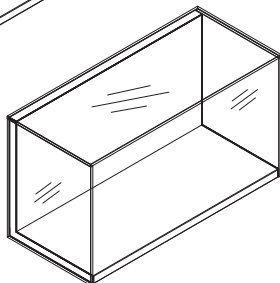
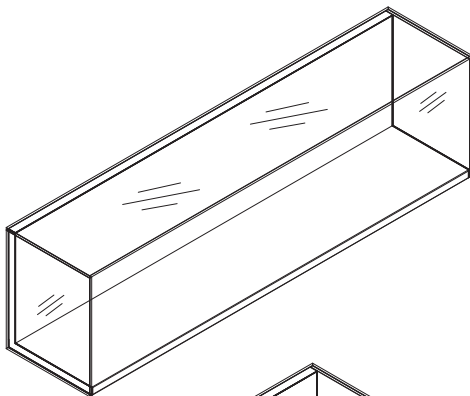
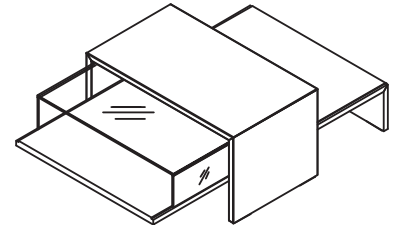
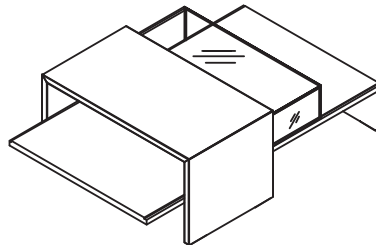
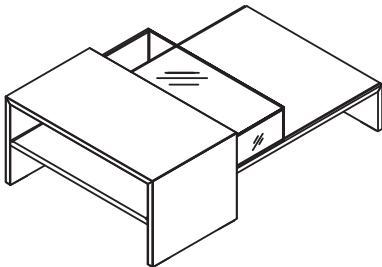
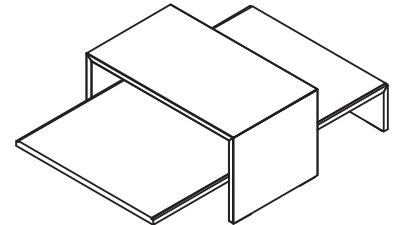
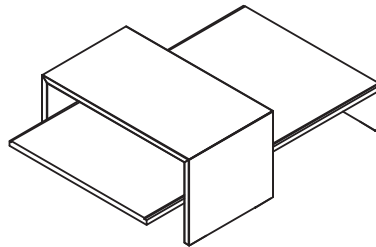
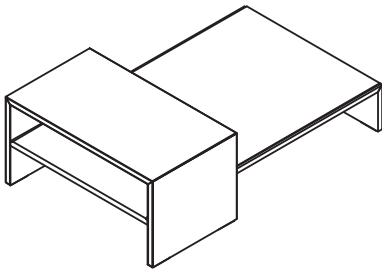

1564829

**Lesen Sie zuerst die Anleitung und beginnen Sie dann mit der Montage**  
Before starting with the fitting, please read carefully the assembly instruction  
*Avant de commencer avec le montage, nous vous prions de bien lire le notice de montage*  
Voordat uw met de montage begint, a.u.b. de montagehandleiding lezen

**SERVICE**

Stand: 08/2015

hülsta-werke · Karl-Hüls-Straße 1 · 48703 Stadthoorn  
TEL.+49 2563 86-0 · FAX +49 2563 86-1417  
www.huelsta.com · info@huelsta.com

# INHALT

## CONTENTS TABLE DES MATIERS INHOUD

### **Couchtisch**

Coffee table · *table basse* · salontafel

3-6

### **Glaswinkelbord**

Right-angled glass shelf · *tablette en L en verre* · glazen boekenplank met wandpaneel

7-14

# MONTAGEANLEITUNG

## COUCHTISCH

COFFEE TABLE / TABLE BASSE / SALONTAFEL

**now!** no.14  
by hülsta

### Für die Montage wird benötigt:

Necessary for assembly:

Pour le montage il faut:

Benodigheden voor de montage:

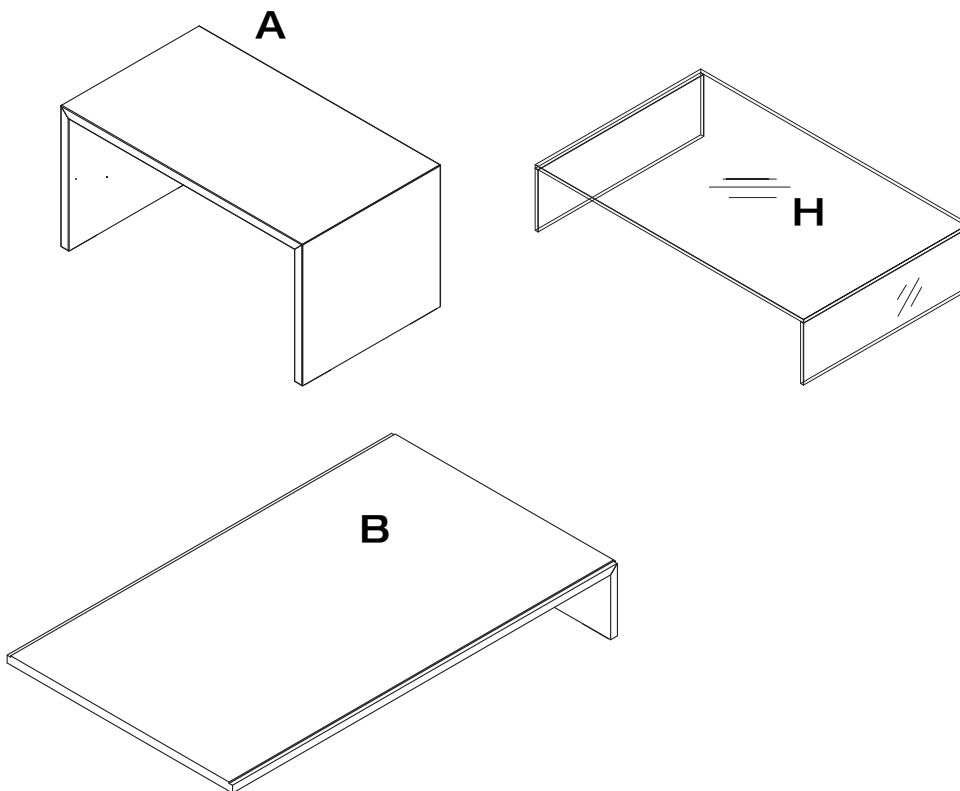
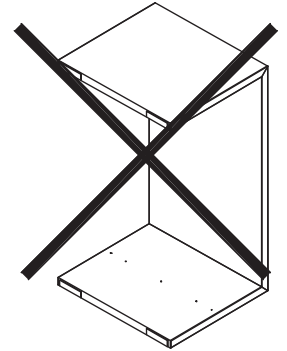
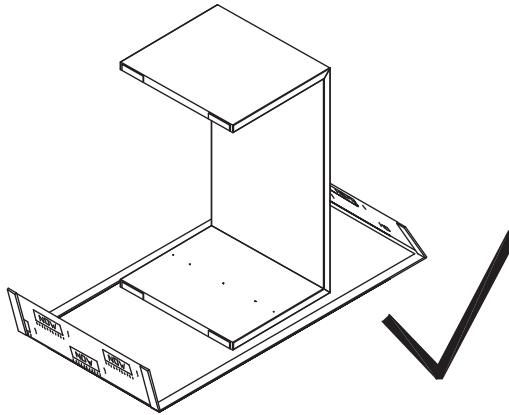
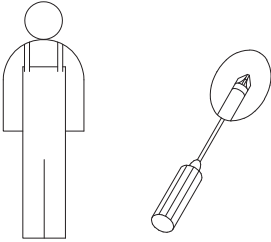

BB 1906 Mat. Nr. 1367239

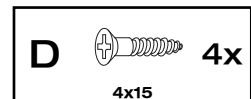
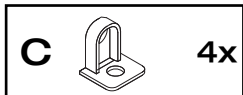

BB 1438 Mat. Nr. 1148653

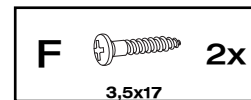
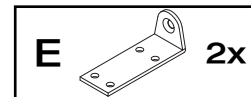

### Verehrter Kunde, hier haben Sie die Möglichkeit die mitgelieferten Schrauben nachzumessen!

Dear customer, here you find a possibility to measure the delivered screws!

*Cher client, ici vous avez la possibilité de mesurer les vis livrées!*

Beste klant, hier heeft uw de mogelijkheid de schroeven te meten!



# MONTAGE COUCHTISCH

ASSEMBLY COFFEE TABLE  
MONTAGE DE TABLE EN BASSE  
MONTAGE SALONTAFEL

**1**

**Position 1**  
Position 1  
Position 1  
Positie 1

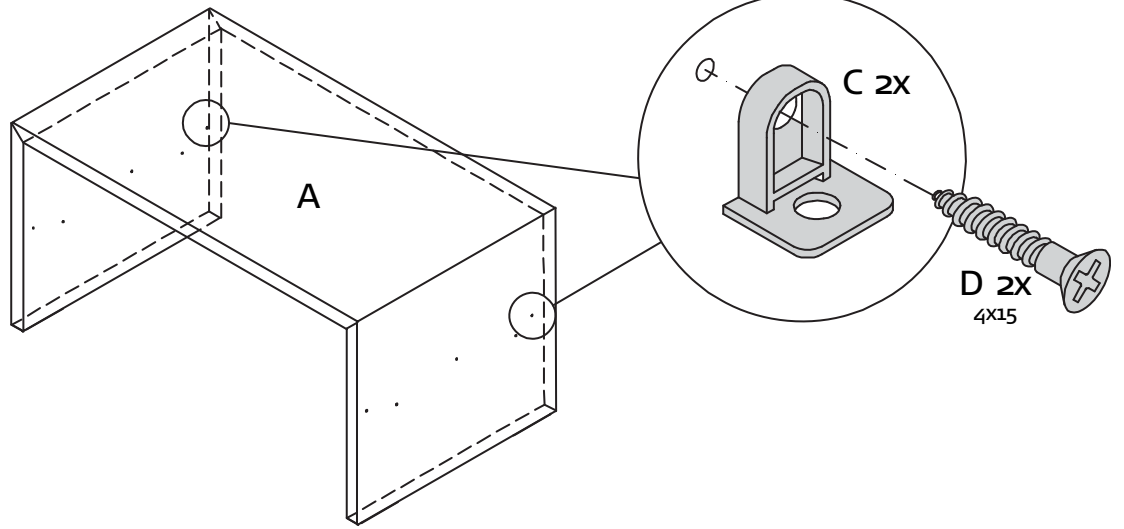
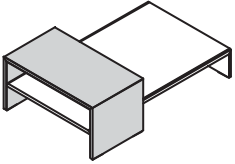

**1**

**Position 2**  
Position 2  
Position 2  
Positie 2

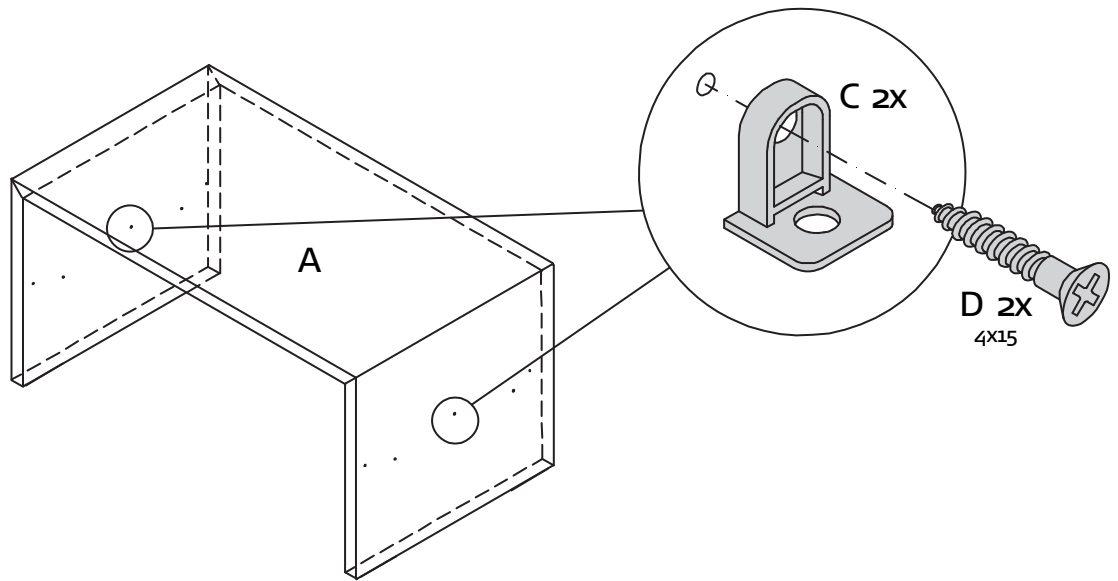
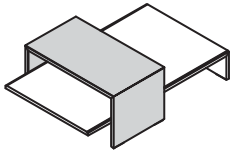

**1**

**Position 3**  
Position 3  
Position 3  
Positie 3

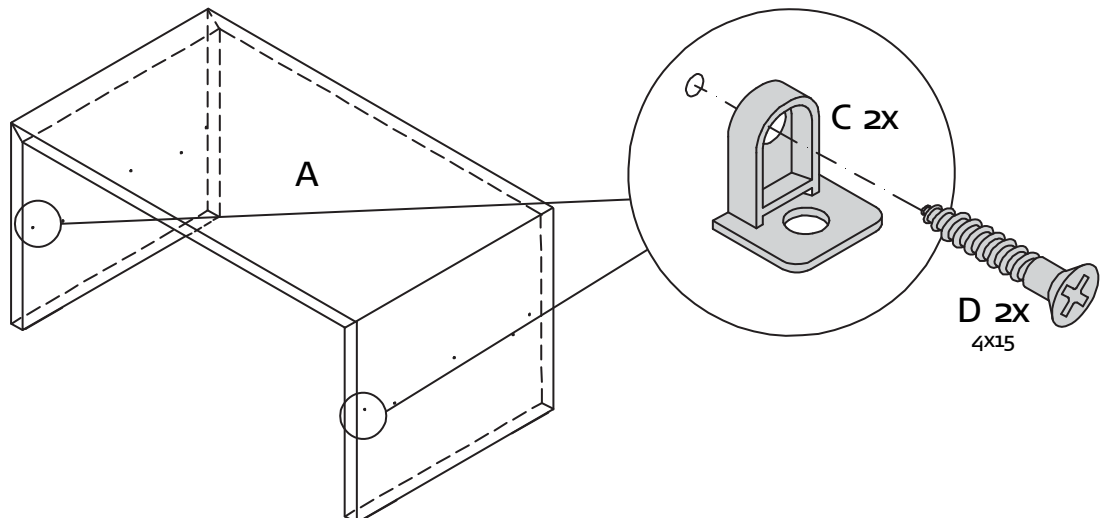
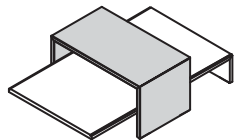

2

Position 1  
Position 1  
Position 1  
Positie 1

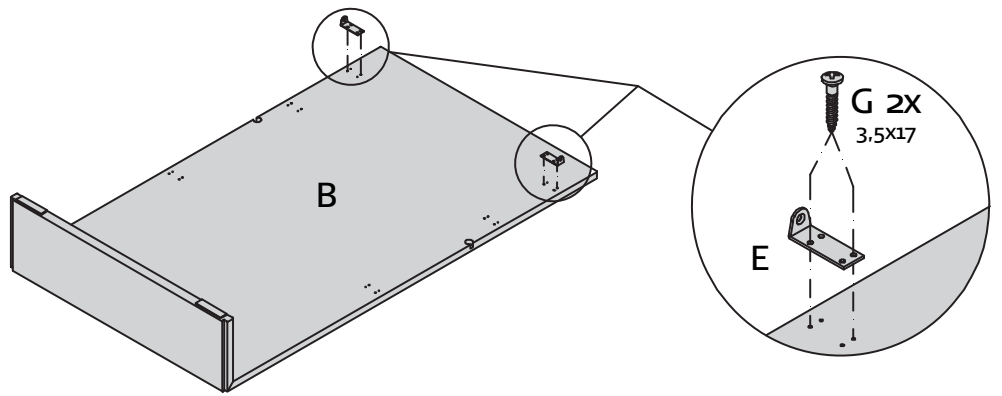
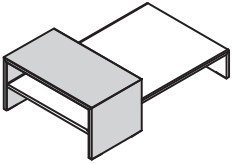

2

Position 2  
Position 2  
Position 2  
Positie 2

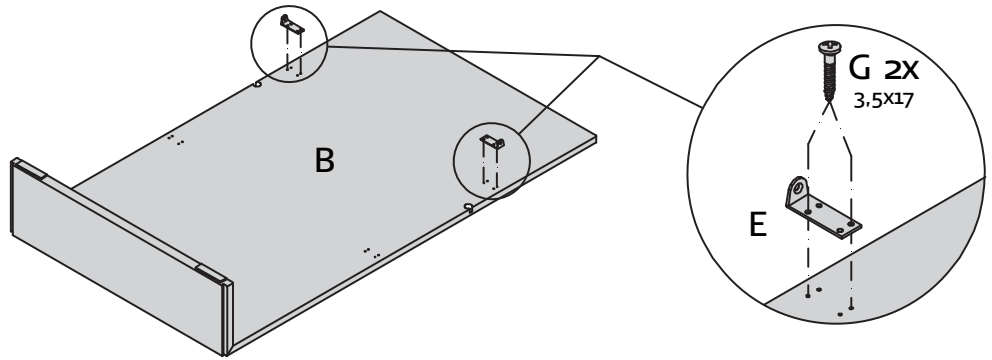
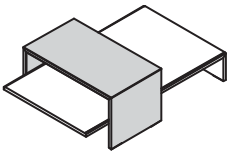

2

Position 3  
Position 3  
Position 3  
Positie 3

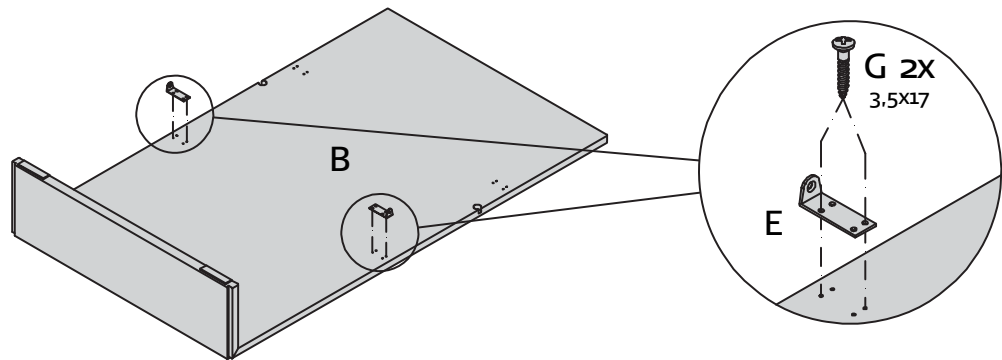
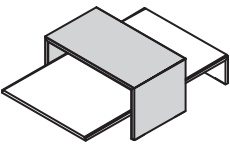

3

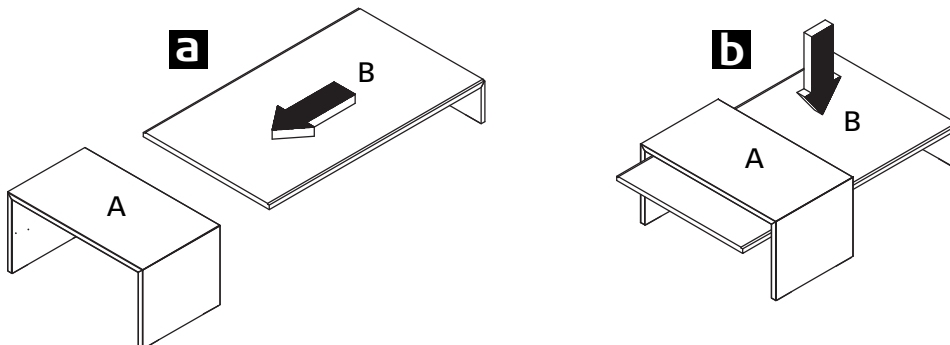

4

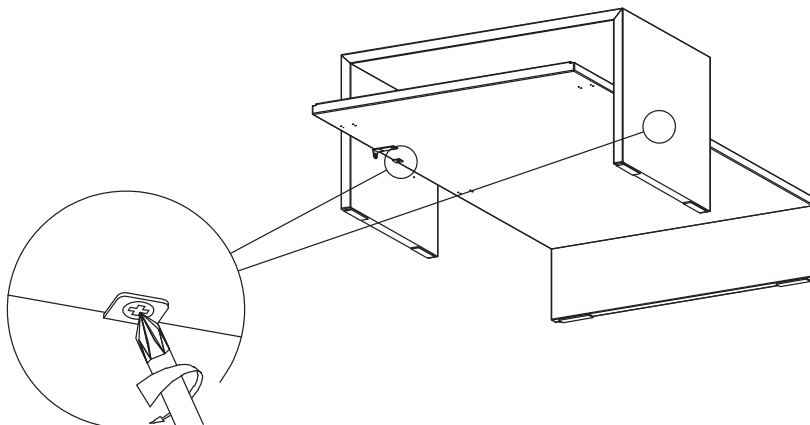

5

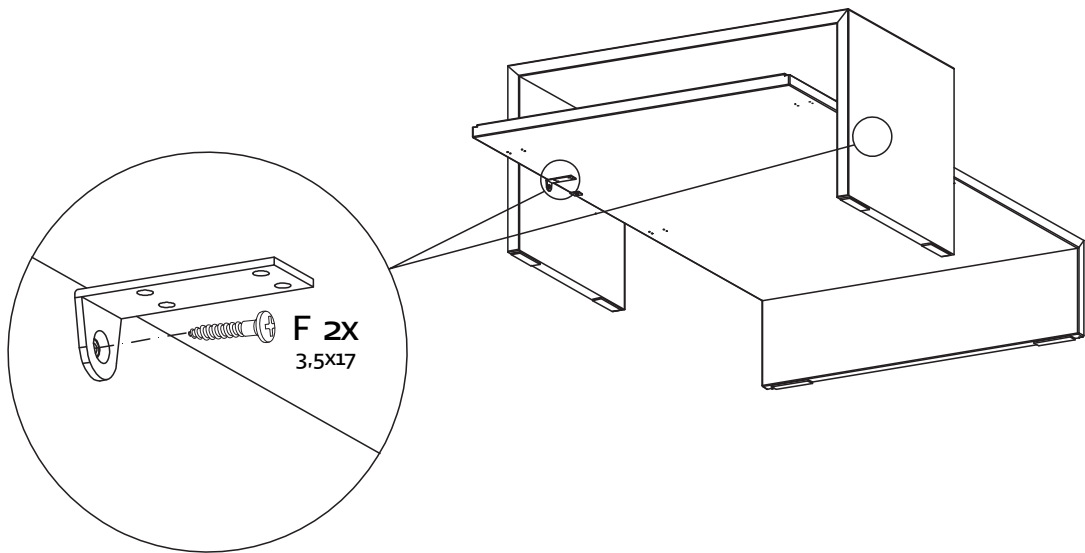

5

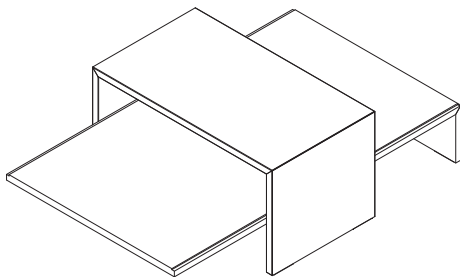

**Achtung! Couchtisch nicht als „Trittleiter“ benutzen!**  
 Caution! Do not use the coffee table as a step ladder!  
 Attention! Ne pas utiliser la table basse comme « escabeau »!  
 N.B.! Salontafel niet als „huishoudtrapje“ gebruiken!

**COUCHTISCH  
 MONTAGE GLASHAUBE  
 TYP 3610**

COFFEE TABLE - ASSEMBLY GLASS BONNET  
 TABLE EN BASSE - MONTAGE DE GARNITURE EN VERRE  
 SALONTAFEL - MONTAGE GLASKAP

1

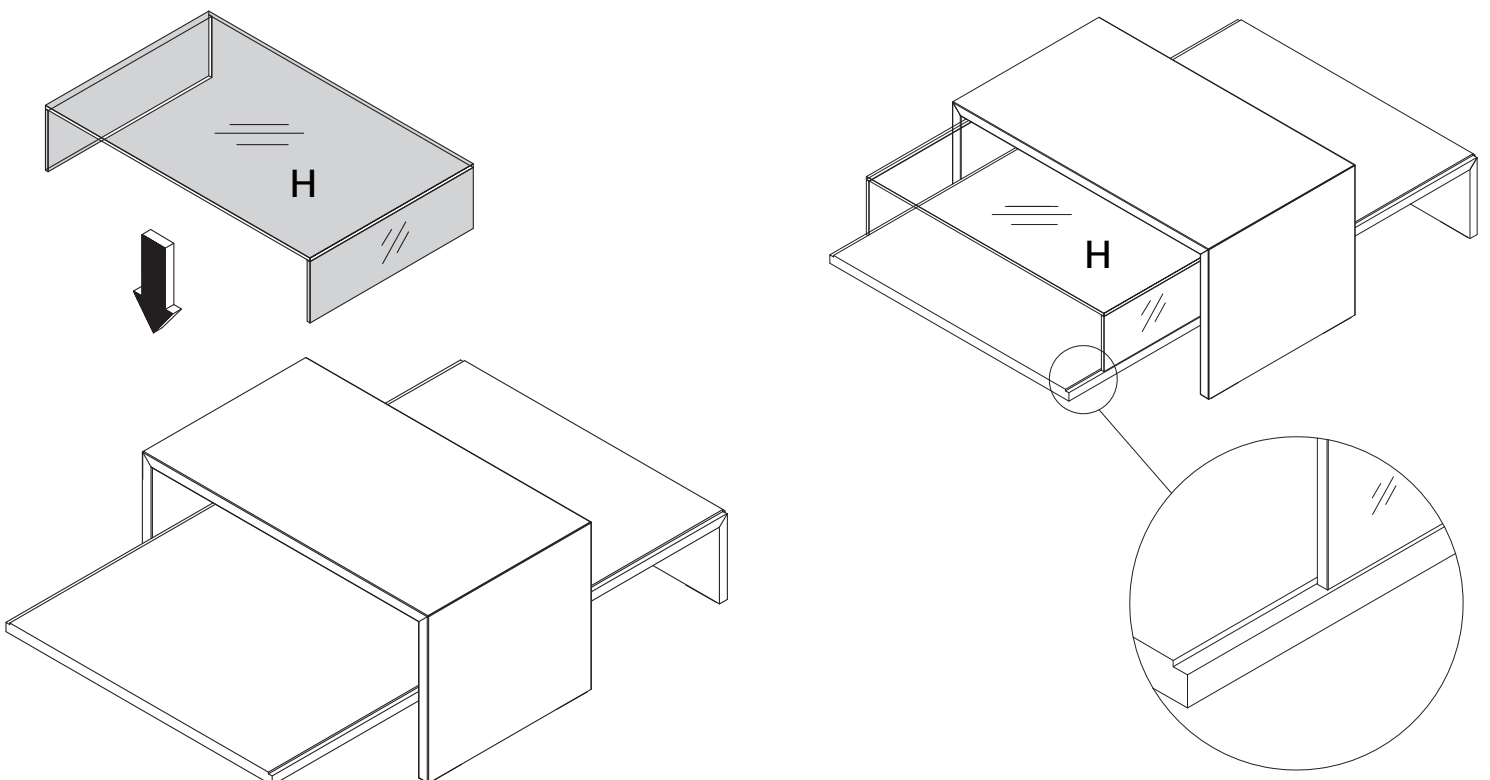

# MONTAGEANLEITUNG

## GLASWINKELBORD

RIGHT-ANGLED GLASS SHELF  
 TABLETTE EN L EN VERRE  
 GLAZEN BOEKENPLANK MET WANDPANEEL

**now!** no.14  
 by hülsta

**Für die Montage wird benötigt:**

Necessary for assembly:

Pour le montage il faut:

Benodigdheden voor de montage:

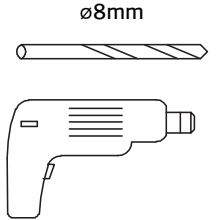
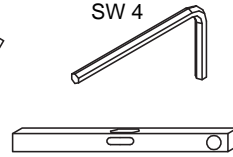
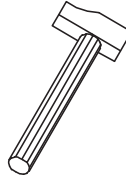
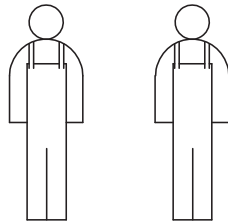

**BK now! 14 Glaswinkelbord 70**

Mat.-Nr.:1365461

BK now! 14 right-angled glass shelf 70 cm wide  
 BK now! 14 tablette en L en verre d'une largeur de 70 cm  
 BK now! 14 glazen boekenplank met wandpaneel  
 in 70 cm breedte

<b>A</b>  2X	<b>D</b>  SW 2 1X
<b>B</b>  7x70 4X	<b>E</b>  ø8mm 4X
<b>C</b>  4x20 8X	<b>F</b>  5x60 4X
<b>G</b>  4x20 8X	<b>H</b>  3X
weiß • white • blanc • wit braunschwarz • brown-black • brun foncé • bruinzwart grau • grey • gris • grijs	

**BK now! 14 Glaswinkelbord 140**

Mat.-Nr.:1365462

BK now! 14 right-angled glass shelf 140 cm wide  
 BK now! 14 tablette en L en verre d'une largeur de 140 cm  
 BK now! 14 glazen boekenplank met wandpaneel  
 in 140 cm breedte

<b>A</b>  3X	<b>D</b>  SW 2 1X
<b>B</b>  7x70 6X	<b>E</b>  ø8mm 6X
<b>C</b>  4x20 12X	<b>F</b>  5x60 6X
<b>G</b>  4x20 9X	<b>H</b>  3X
weiß • white • blanc • wit braunschwarz • brown-black • brun foncé • bruinzwart grau • grey • gris • grijs	

## Glaswinkelbord 70er Breite Typ 3782

Right-angled glass shelf 70 cm wide  
type 3782  
*Tablette en L en verre d'une largeur de 70 cm  
réf. 3782*  
Glazen boekenplank met wandpaneel  
in 70 cm breedte  
type 3782

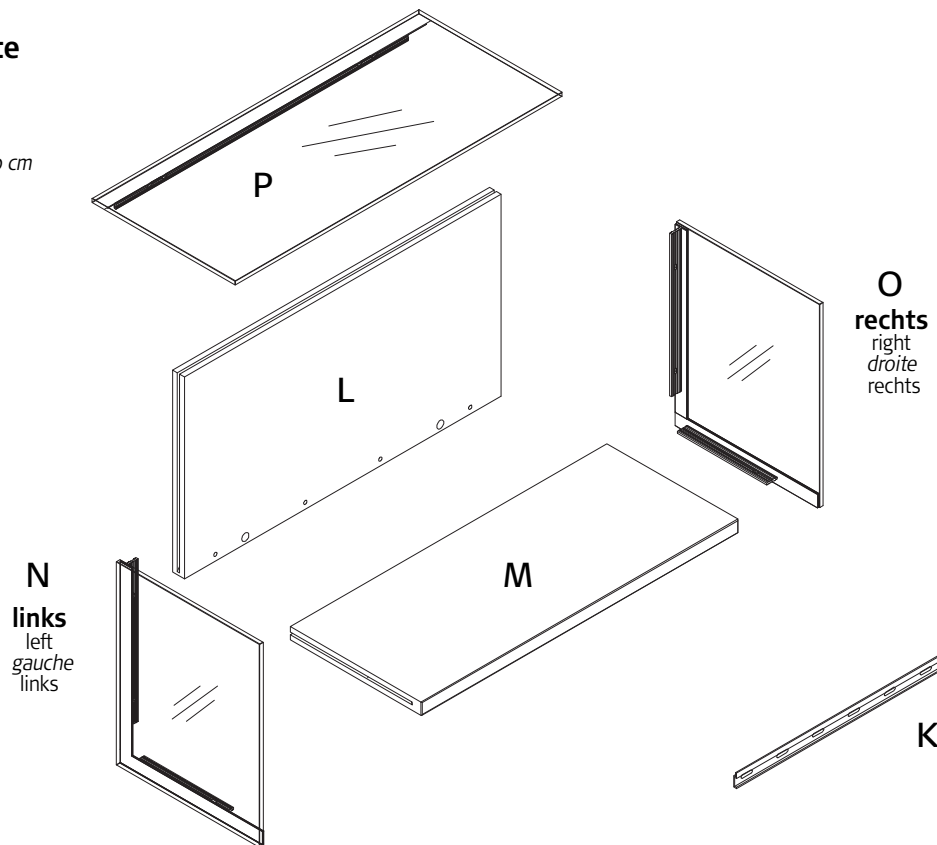

## Glaswinkelbord 140er Breite Typ 3752

Right-angled glass shelf 140 cm wide  
type 3752  
*Tablette en L en verre d'une largeur de 140 cm  
réf. 3752*  
Glazen boekenplank met wandpaneel  
in 140 cm breedte  
type 3752

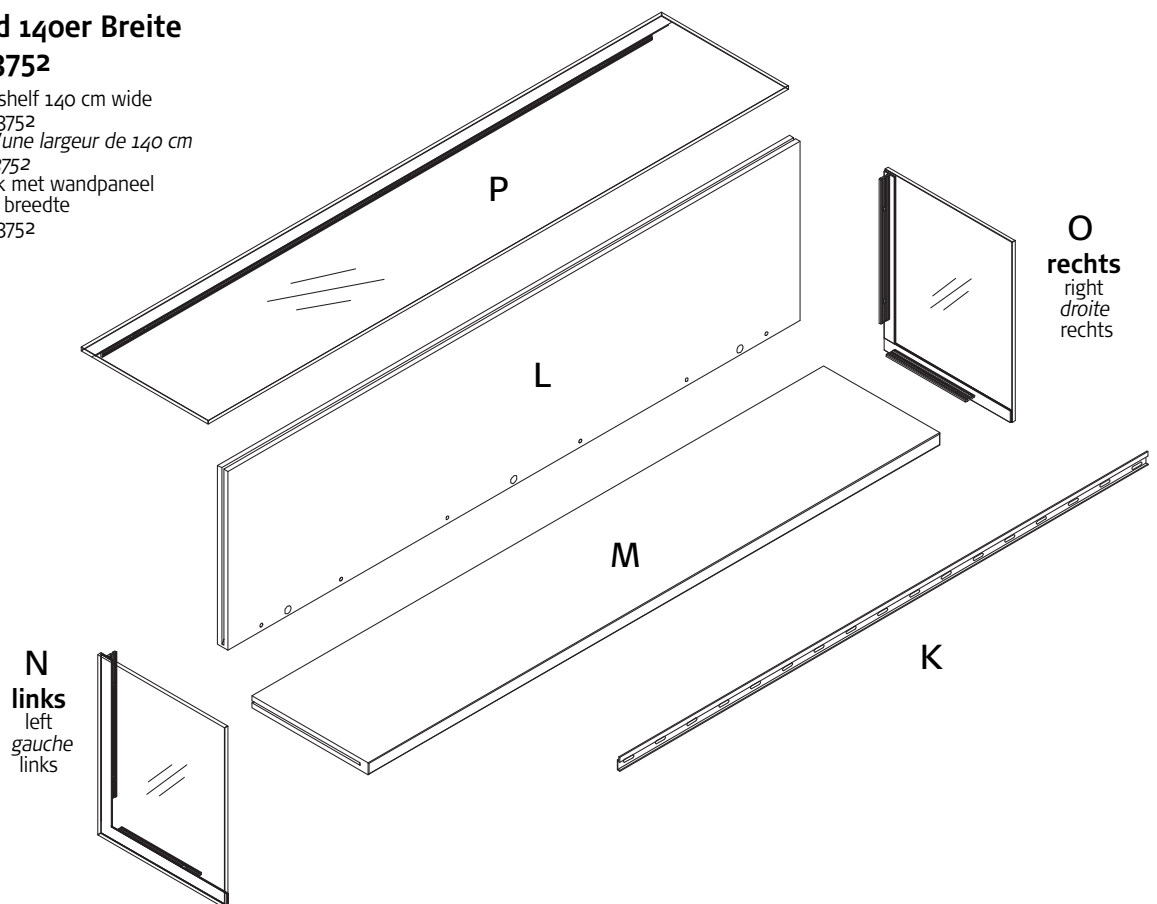



# MONTAGE GLASWINKELBORD

ASSEMBLY RIGHT-ANGLED GLASS SHELF  
MONTAGE TABLETTE EN L EN VERRE  
MONTAGE GLAZEN BOEKENPLANK MET WANDPANEEL

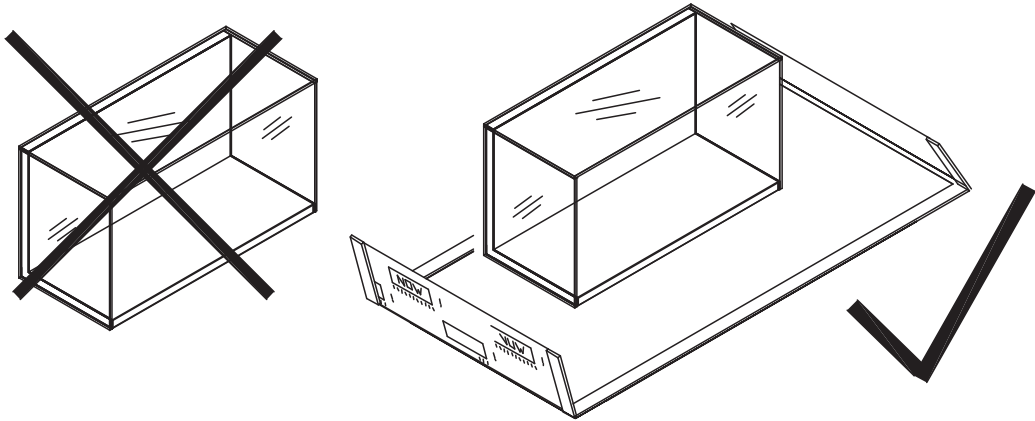

1

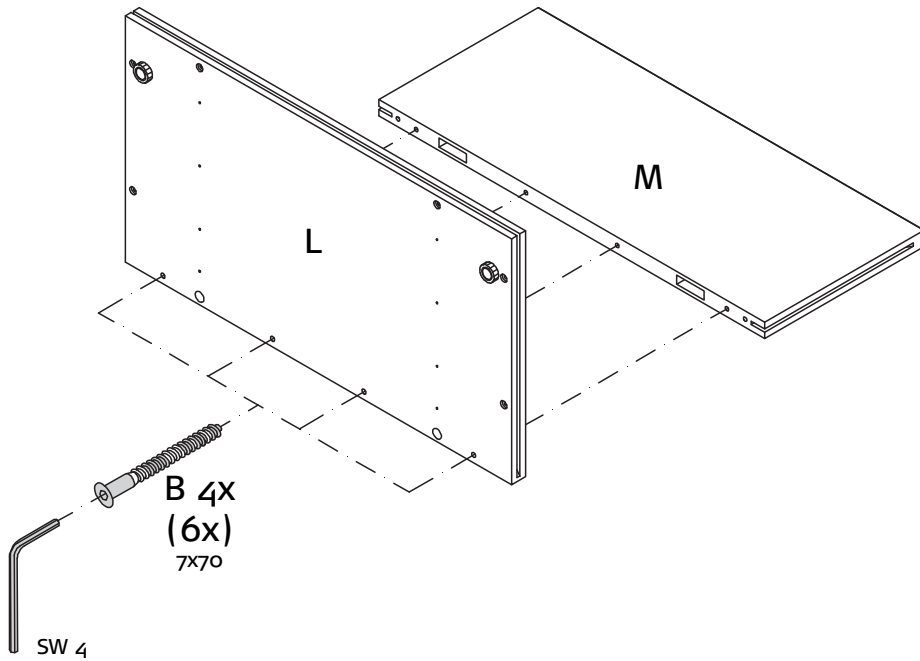

2

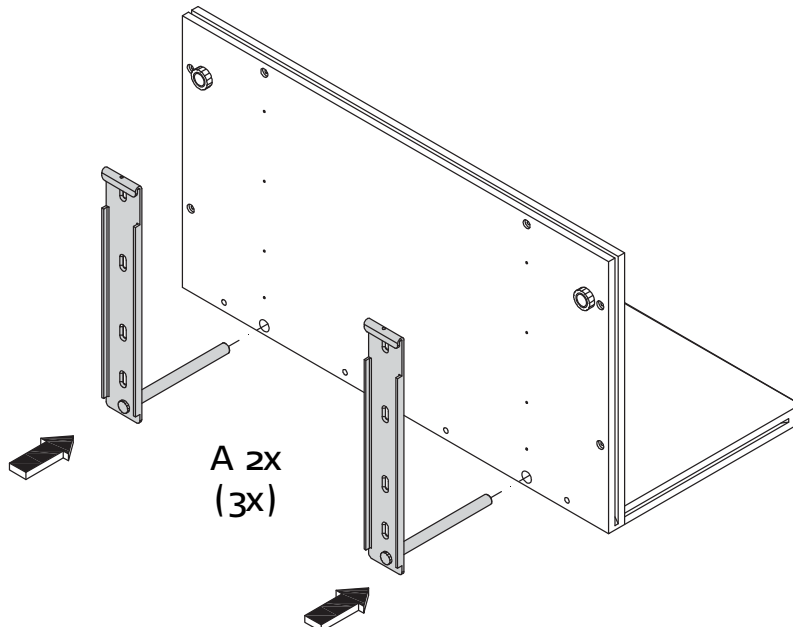

3

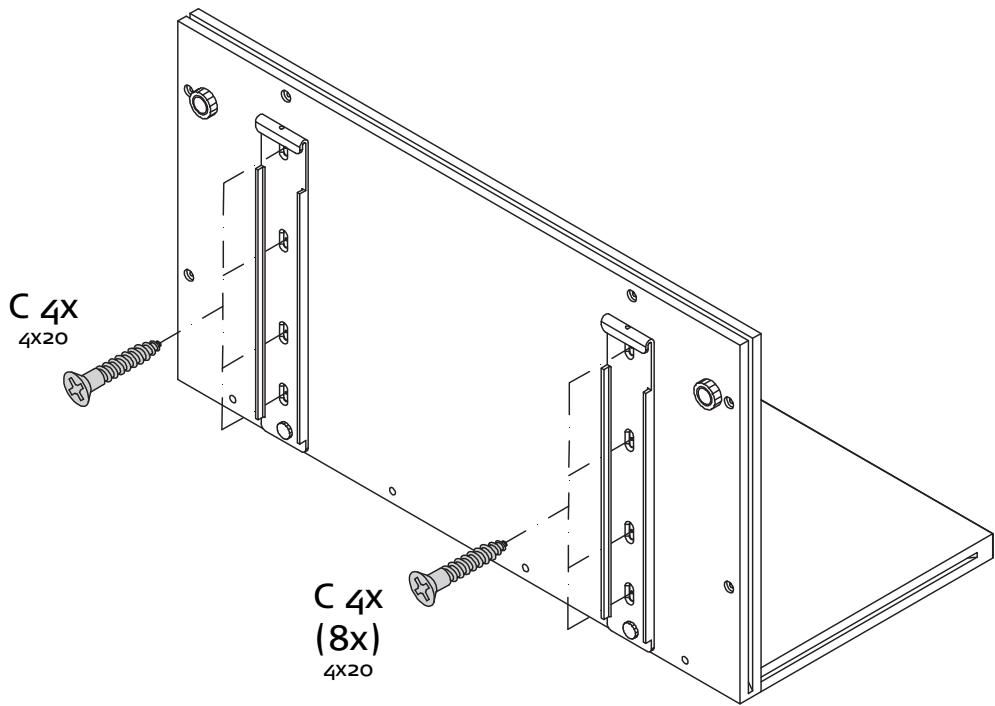

4

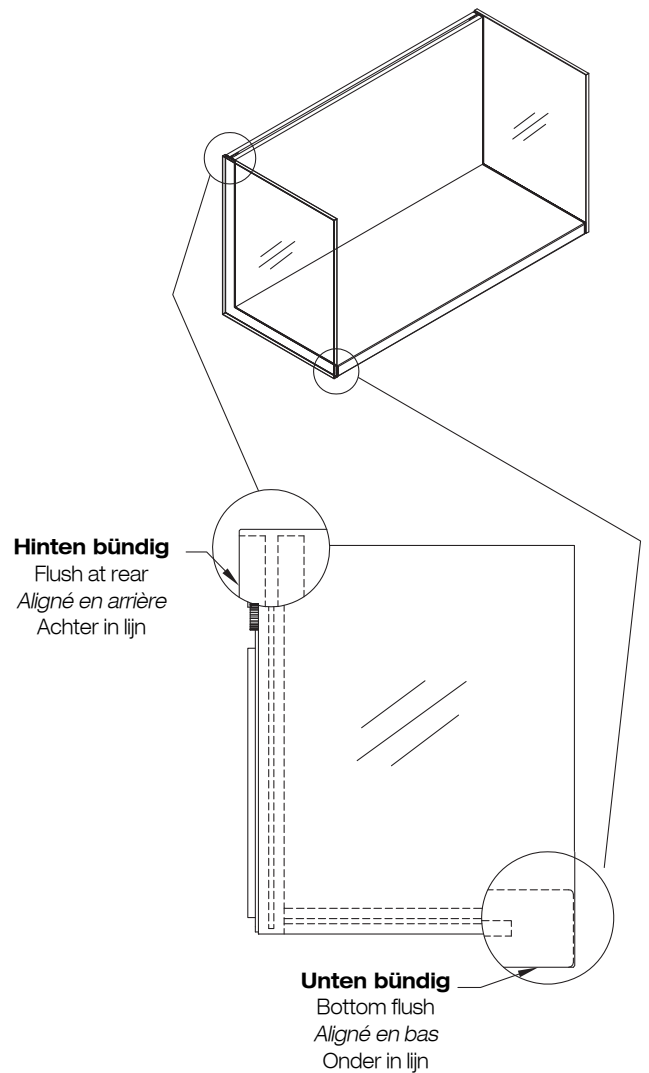
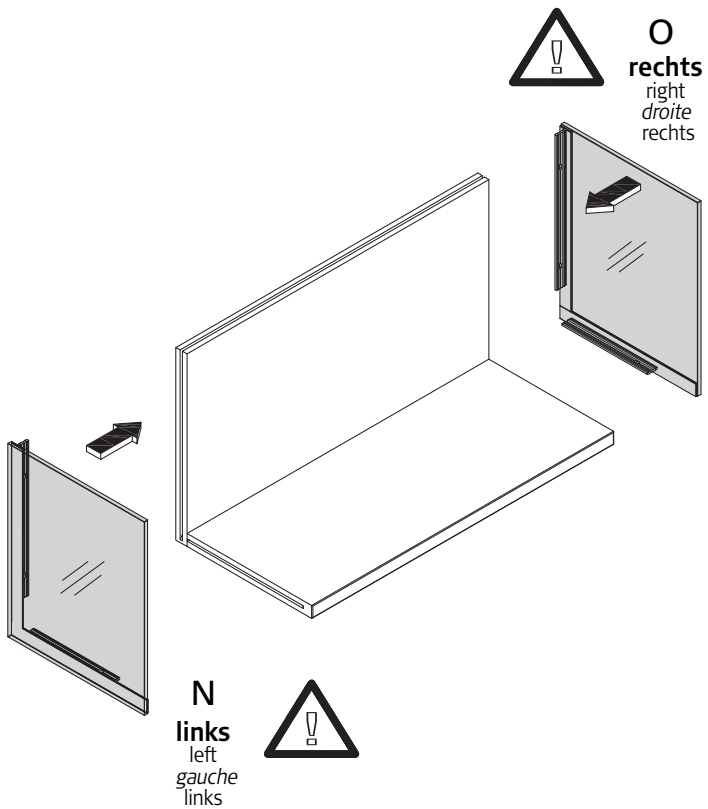

5

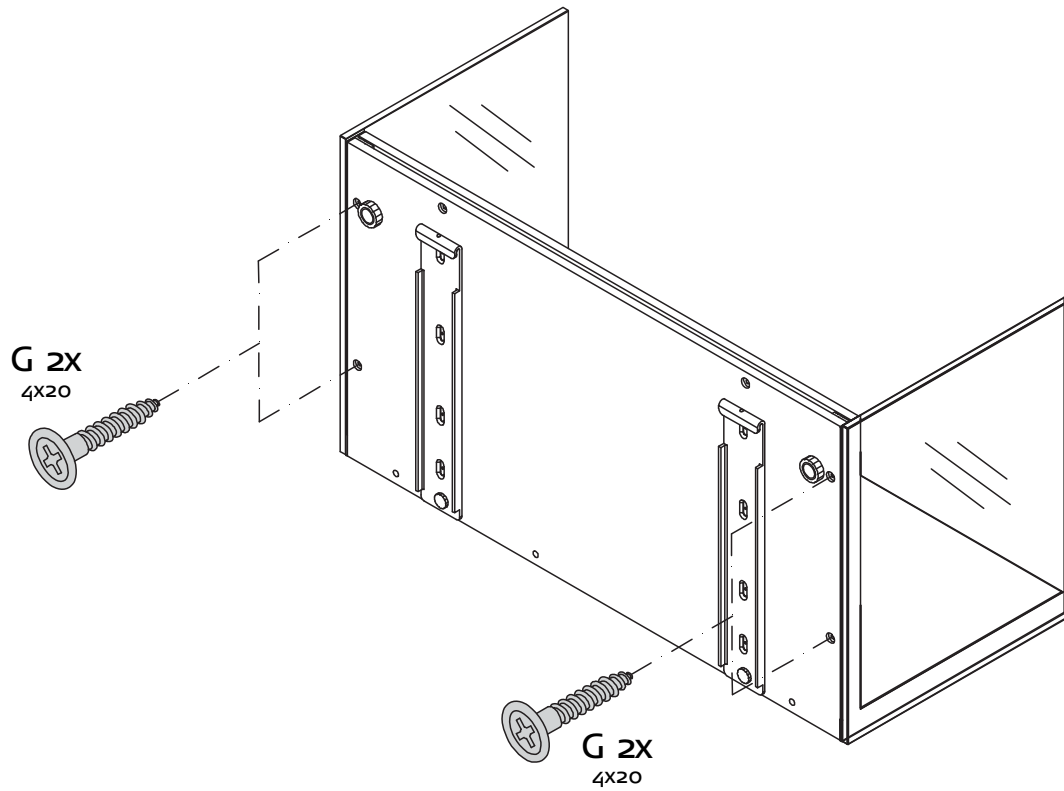

6

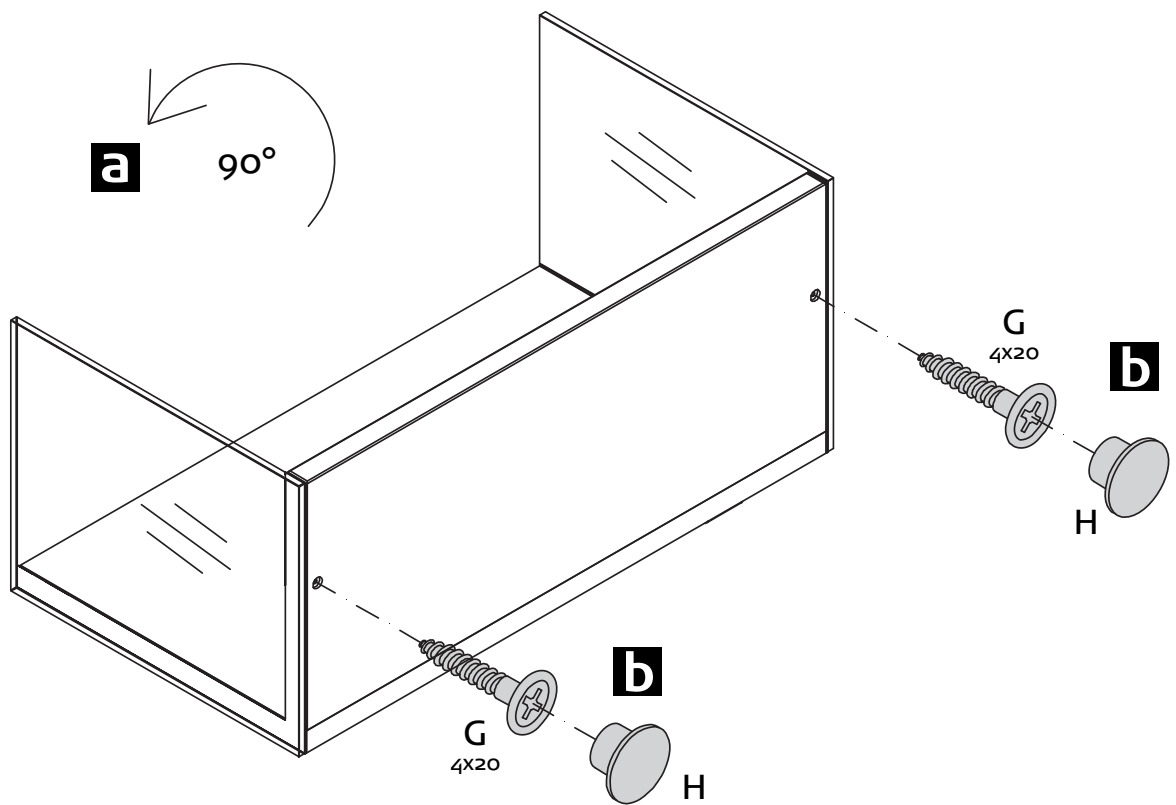

7

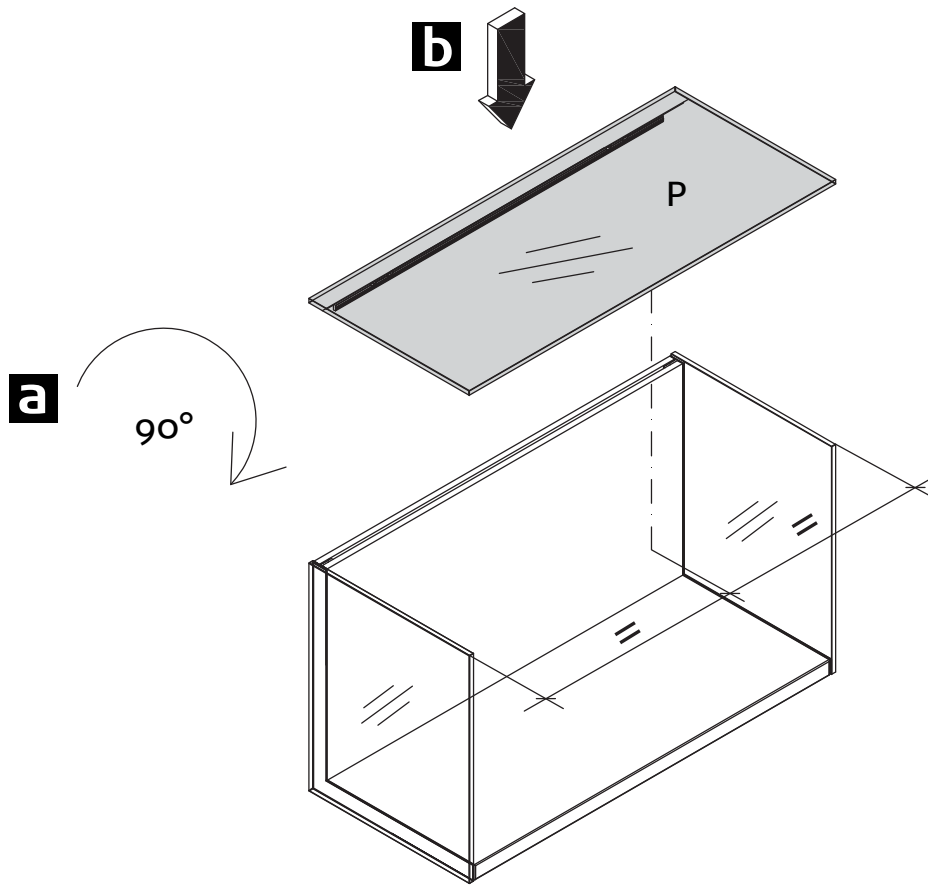

8

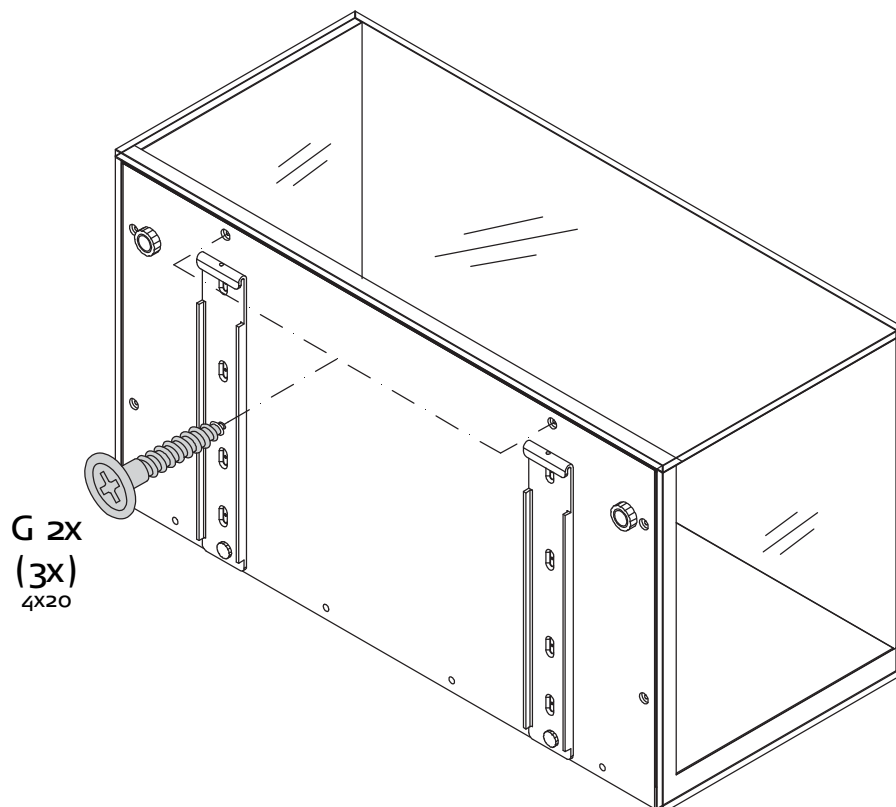

9

## Glaswinkelbord 70er Breite Typ 3782

Right-angled glass shelf 70 cm wide  
type 3782  
*Tablette en L en verre d'une largeur de 70  
réf. 3782*  
Glazen boekenplank met wandpaneel  
in 70 cm breedte  
type 3782

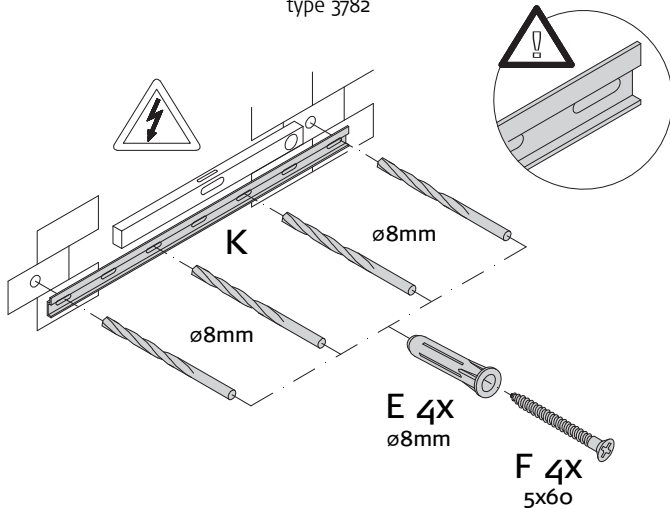

## Glaswinkelbord 140er Breite Typ 37520 / 37510

Right-angled glass shelf 140 cm wide  
type 3752  
*Tablette en L en verre d'une largeur de 140 cm  
réf. 3752*  
Glazen boekenplank met wandpaneel  
in 140 cm breedte  
type 3752

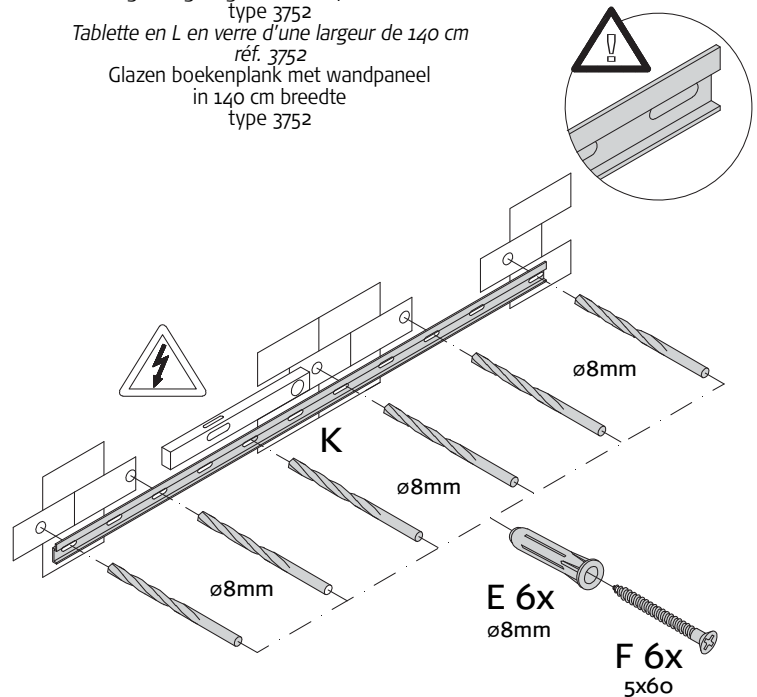

### Gefahr bei fehlerhafter Montage!

Danger if not properly fitted!  
*Danger lors d'un montage incorrect!*  
Attentie! Een verkeerde montage kan gevaarlijk zijn!

### Wandbefestigung

**Achtung!** Die Wandbeschaffenheit ist vor der Montage unbedingt zu prüfen. Verwendung von Dübeln bei Beton und/oder festem Mauerwerk. Bei abweichender Beschaffenheit (z.B. Rahmenbauweise mit Gipskartonplatten, Leichtbausteinen etc.) ist eine andere, der Belastung angemessene Befestigung bauseits vorzunehmen. Beachten Sie, dass in dem Befestigungsbereich keine Elektro-Installationszonen und keine Ver- oder Entsorgungsleitungen vorhanden sein dürfen. Prüfen Sie mit einem geeigneten Leitungssuchgerät. Beachten Sie, dass Kunststoffrohre nicht dedektiert werden.

### Wall mounting

Please note! Please be sure to test the soundness of walls beforehand. Use plugs for concrete and solid walls. Use a different method that is capable of withstanding the load for lighter types of walls (e.g. framed gypsum plaster board, light brickwork, etc.). Please note that there must not be any electrical installations nor any electrical connections or leads of any kind in the assembly area. Please ensure this is so by testing the area with a suitable electrical leads search device. Please also note that plastic tubing will not be detected.

### Fixation murale

**Attention!** La composition du mur doit absolument être contrôlée. Utilisation de chevilles pour le béton et/ou la maçonnerie dure. Pour les autres types de construction (cloisons en placoplâtre, maçonnerie légère, etc...), il faut prévoir un autre mode de fixation en rapport avec la charge. Veuillez contrôler l'absence d'installations électriques et de conduits dans le secteur de la fixation à l'aide d'un appareil. Veuillez noter que les tubes en matière synthétiques ne sont pas détectés.

### Bevestiging aan de muur

Attentie! Controleer, alvorens te beginnen, altijd de aard en de kwaliteit van de muur, waaraan gemonteerd moet worden. Gebruik voor de bevestiging aan beton en schoon metselwerk de door hülsta meegeleverde standaard pluggen en passende schroeven. In geval van muren van een ander, lichter soort materiaal (bijv. gipsplaten op een raamwerk of lichte bouwstenen) moet een ander, aan het draagvermogen aangepast speciaal bevestigingsmateriaal gebruikt worden. N.B.! In het muurgedeelte waar gemonteerd moet worden, mogen zich geen elektro-installatiezones bevinden resp. mogen geen aan- en/of afvoertleidingen (buizen) lopen. Dit kan gecontroleerd worden met speciale daarvoor bestemde detectieapparatuur. N.B.! Kunststofleidingen kunnen helaas niet worden gedetecteerd.

10

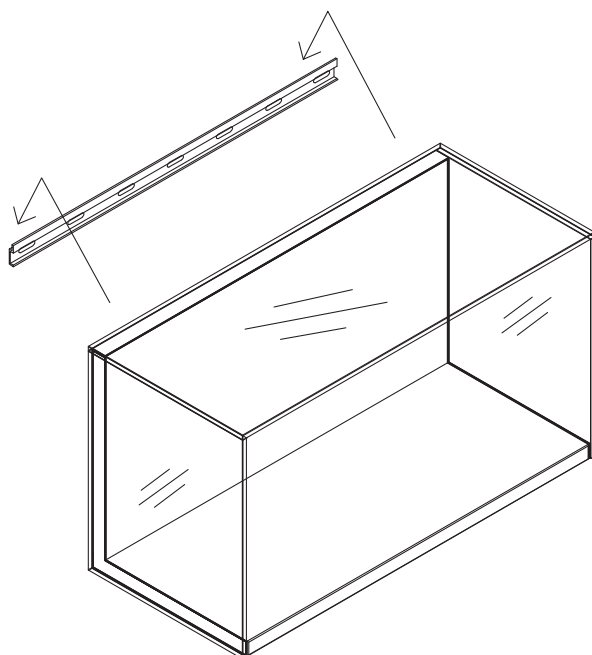

11

**Tiefeneinstellung**  
Depth adjustment  
*Réglage en profondeur*  
Diepteverstelling

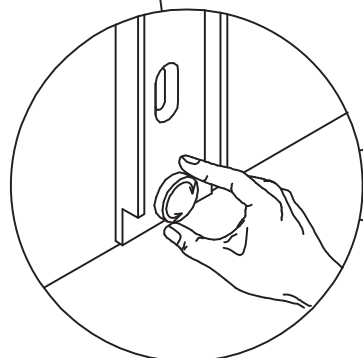
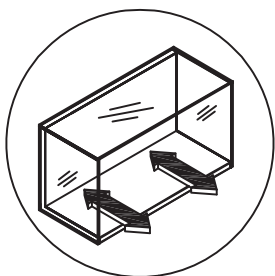

**Höhenausgleich**  
Height adjustment  
*Réglage en hauteur*  
Hoogteverstelling

**Einstellmöglichkeit 1-5 mm**  
Possible adjustment 1-5 mm  
*Possibilité de réglage 1-5 mm*  
Instelmogelijkheid 1-5 mm

