

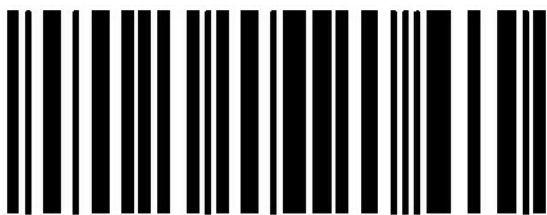

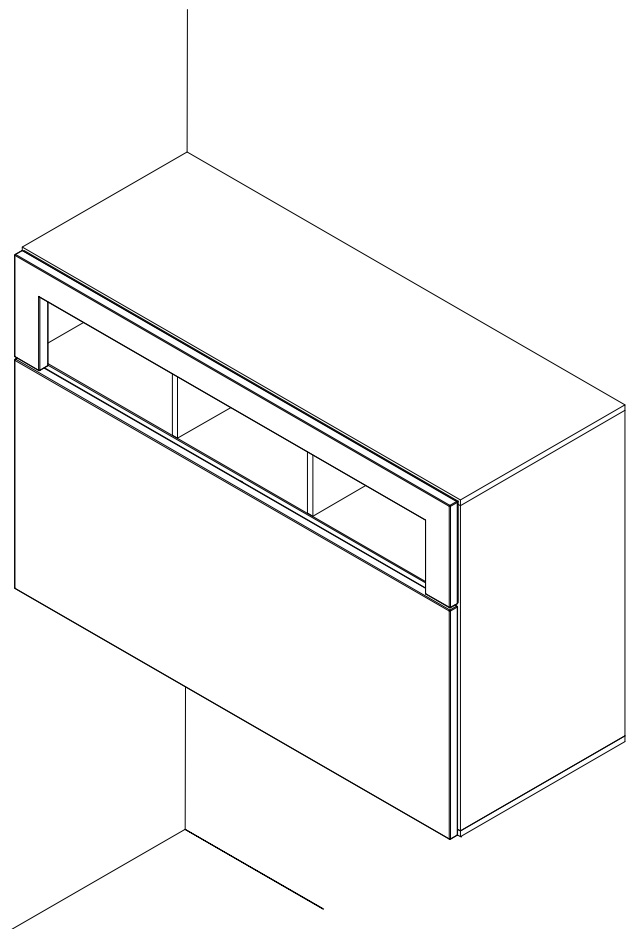

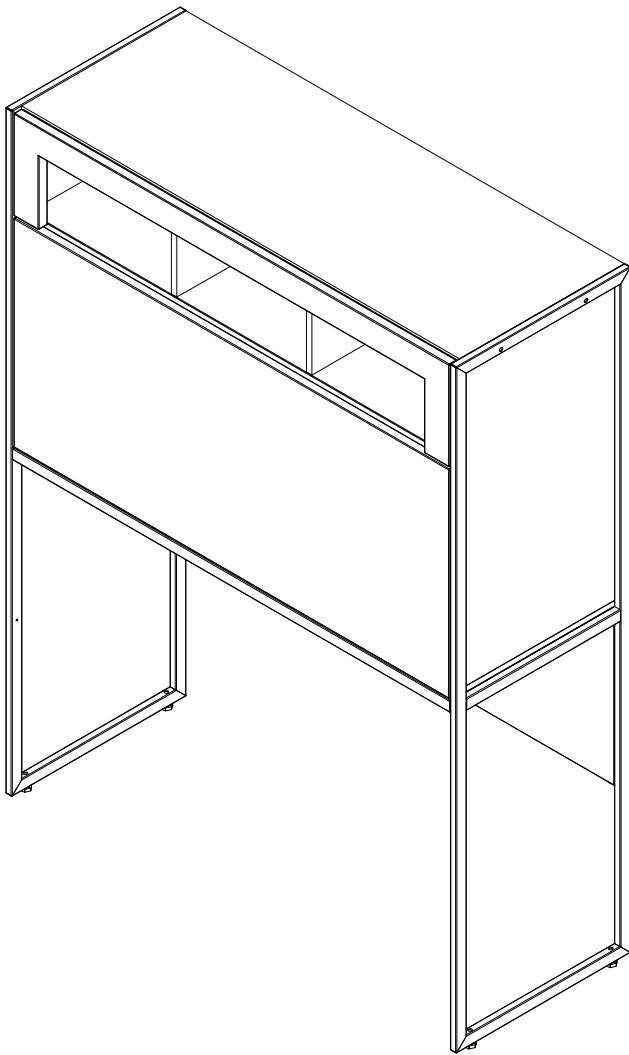

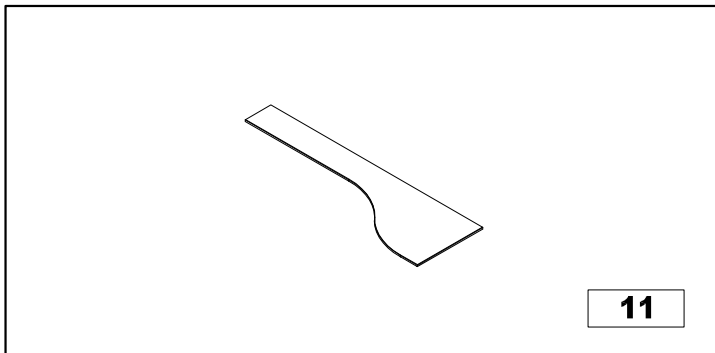

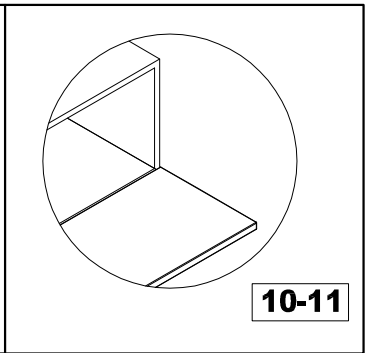
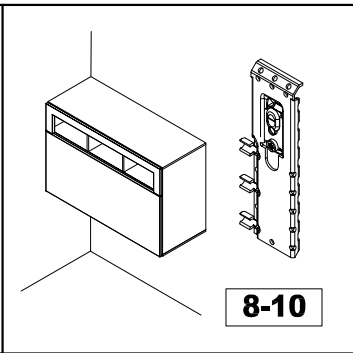
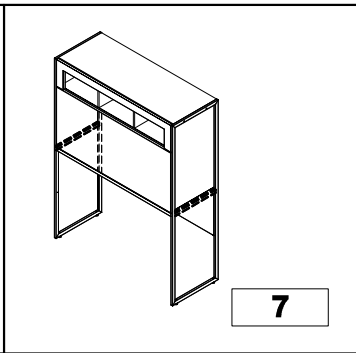
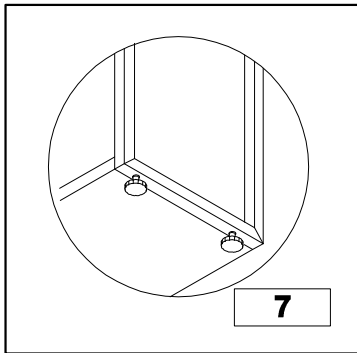
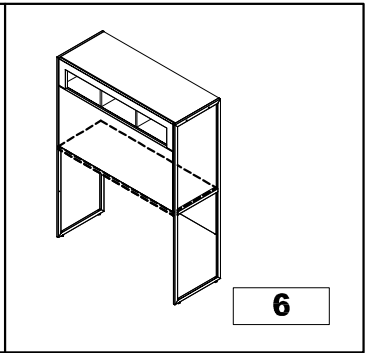
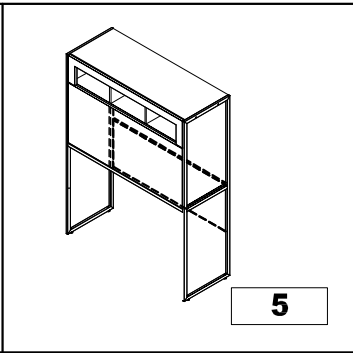
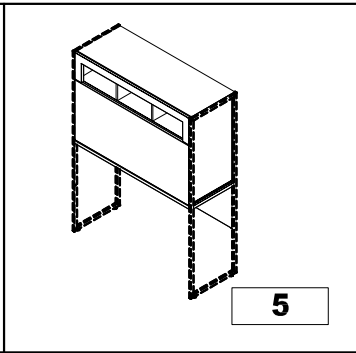
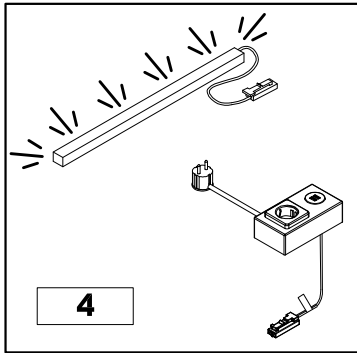
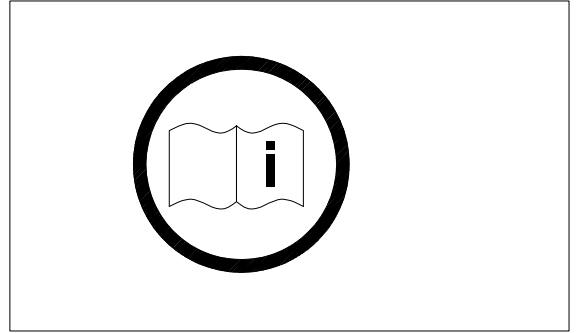
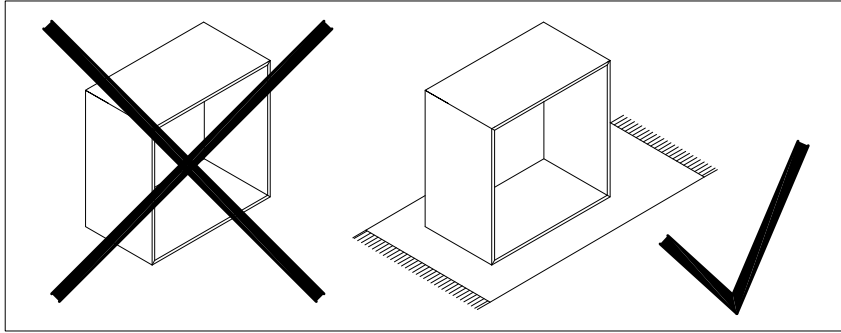
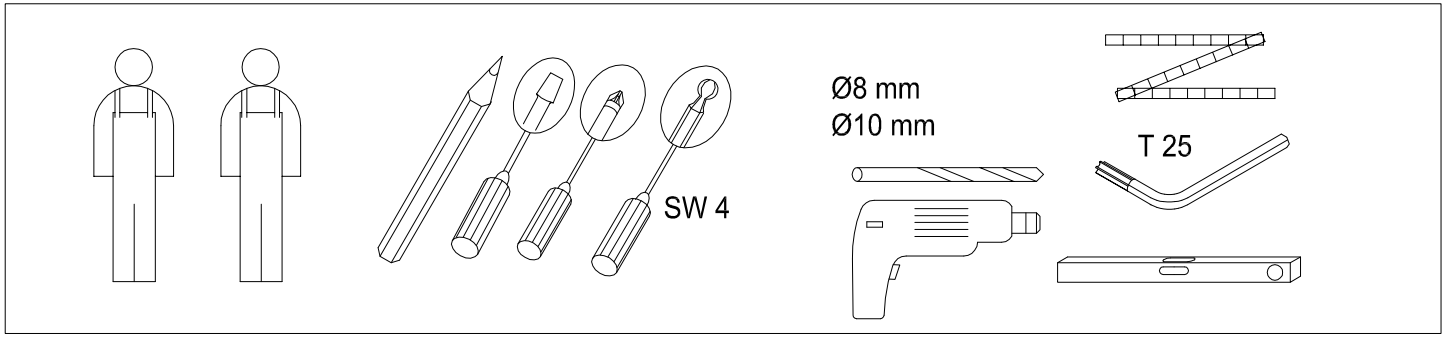



now vision







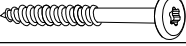
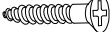
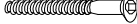







1731122

hülsta-werke · Karl-Hüls-Straße 1 · 48703 Stadtlohn
TEL +49 2563 86-0 · FAX +49 2563 86-1417
www.huelsta.com 12 / 2020

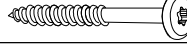
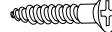

BB 809			Mat. 964935		
4x					
4x					
BB 902			Mat. 279867		
4x			3,5x15		
4x					
BB 2166 / 2170 / 2714			Mat. Nr.1502163 / 1502167 / 1704560		
10					
12x					
BB 2375/2376/2377			Mat. 1557331/1557332/1557333		
2x					
BB 2387			Mat. 1559090		
4x			3,5x17		
BB 2406			Mat. 1561343		
4x					
4x			4x8		
BB 2460			Mat. 1535746		
4x			Ø8 mm		
4x			6x70		
BB 2651			Mat. 1658427		
5x			4,5x35		
BB 2743			Mat. 1712418		
4x			5x50		
BB 2108			Mat. 1466224		
4x			5x24		

BB 809			Mat. 964935		
4x					
4x					
BB 902			Mat. 279867		
4x			3,5x15		
4x					
BB 2166 / 2170 / 2714			Mat. Nr.1502163 / 1502167 / 1704560		
10					
12x					
BB 2375/2376/2377			Mat. 1557331/1557332/1557333		
2x					
BB 2387			Mat. 1559090		
4x			3,5x17		
BB 2406			Mat. 1561343		
4x					
4x			4x8		
BB 2460			Mat. 1535746		
4x			Ø8 mm		
4x			6x70		
BB 2651			Mat. 1658427		
5x			4,5x35		
BB 2743			Mat. 1712418		
4x			5x50		
BB 2108			Mat. 1466224		
4x			5x24		

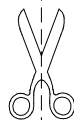

1

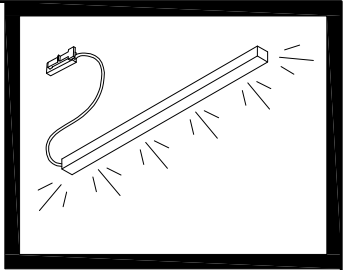
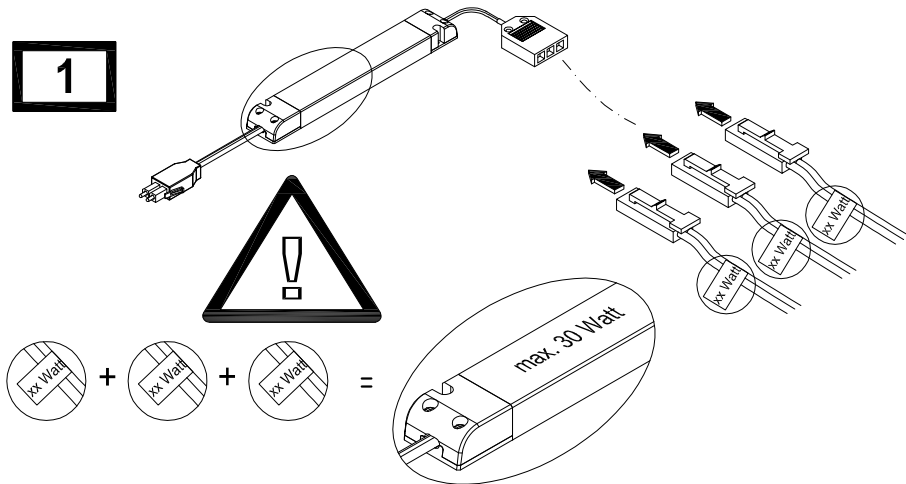

2

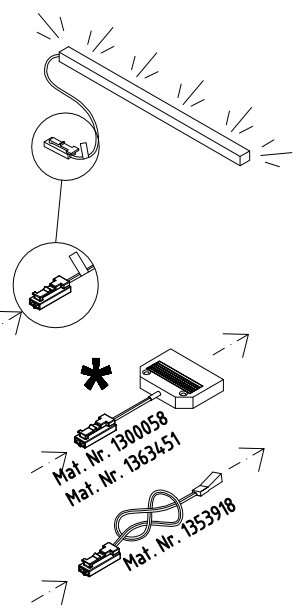
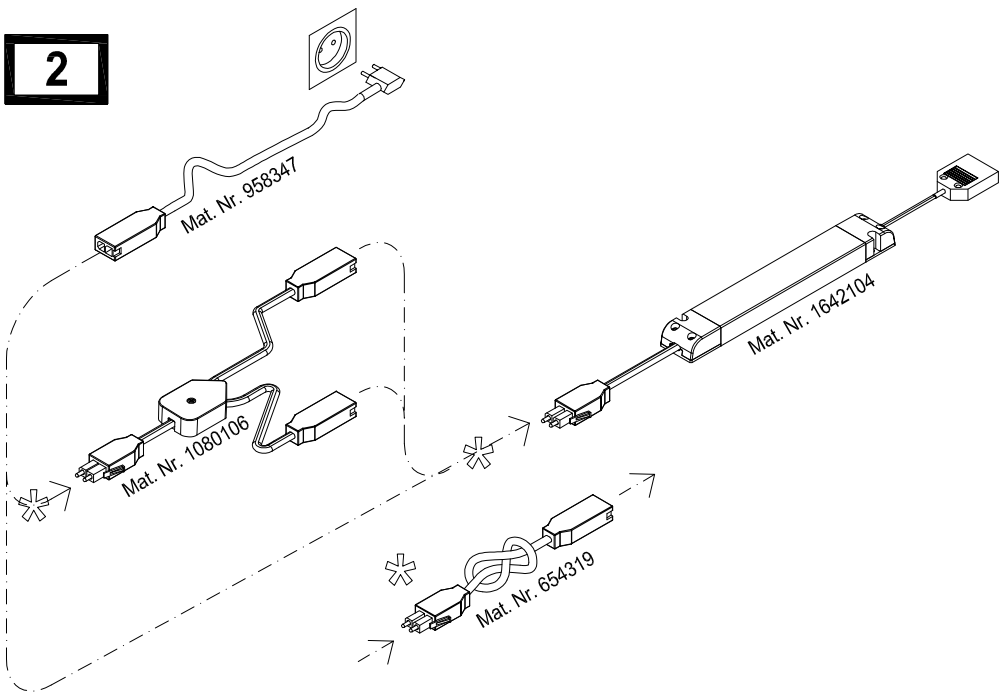

1

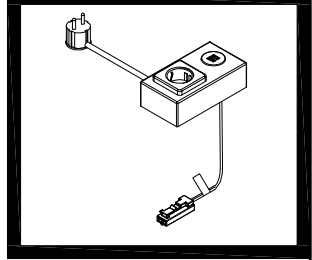
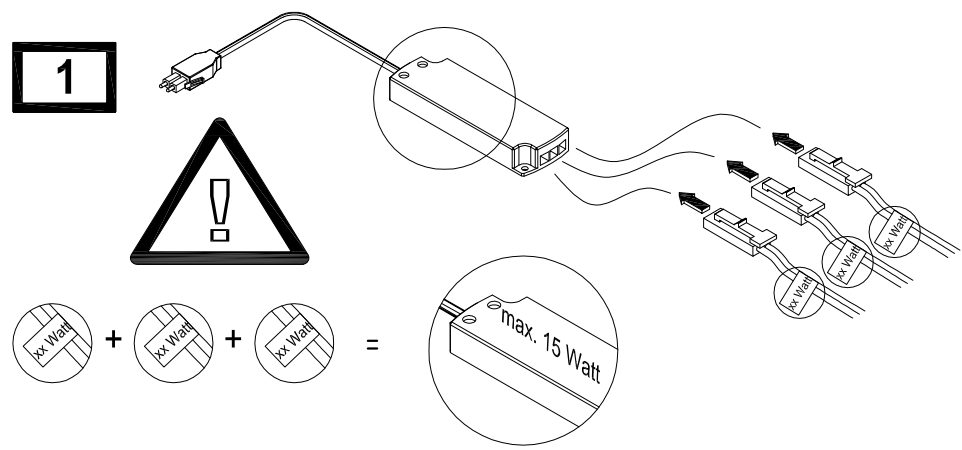

2

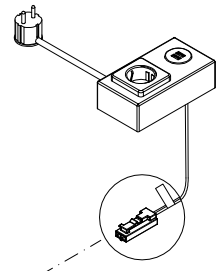
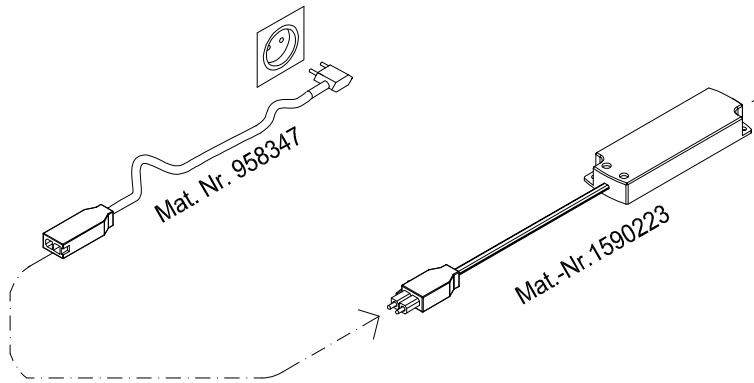

1

BB 2406

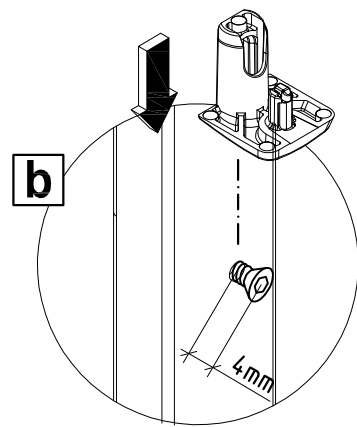
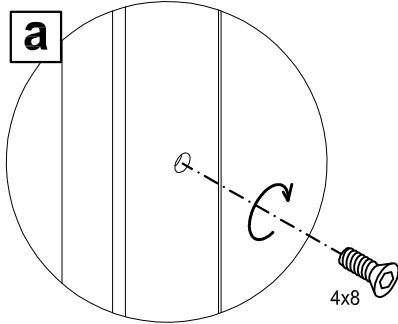
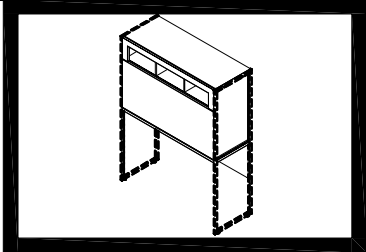
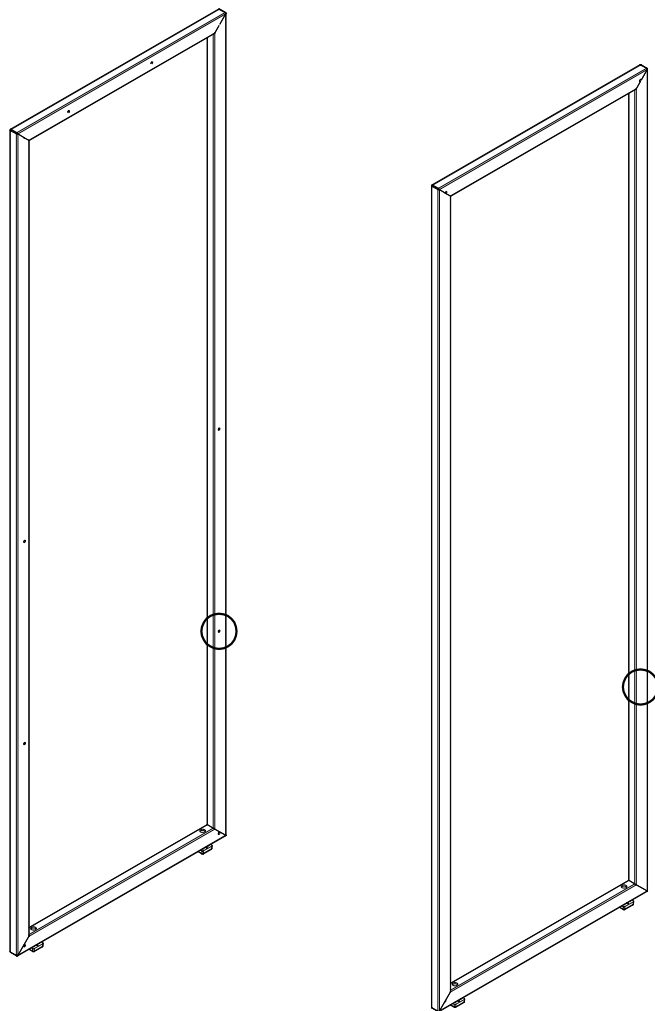

1

BB 809

b

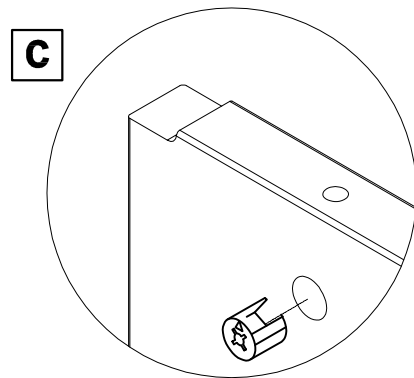
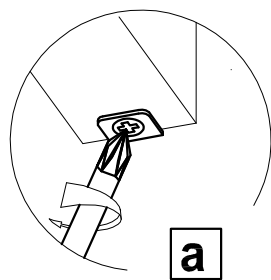
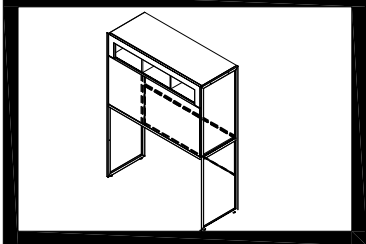
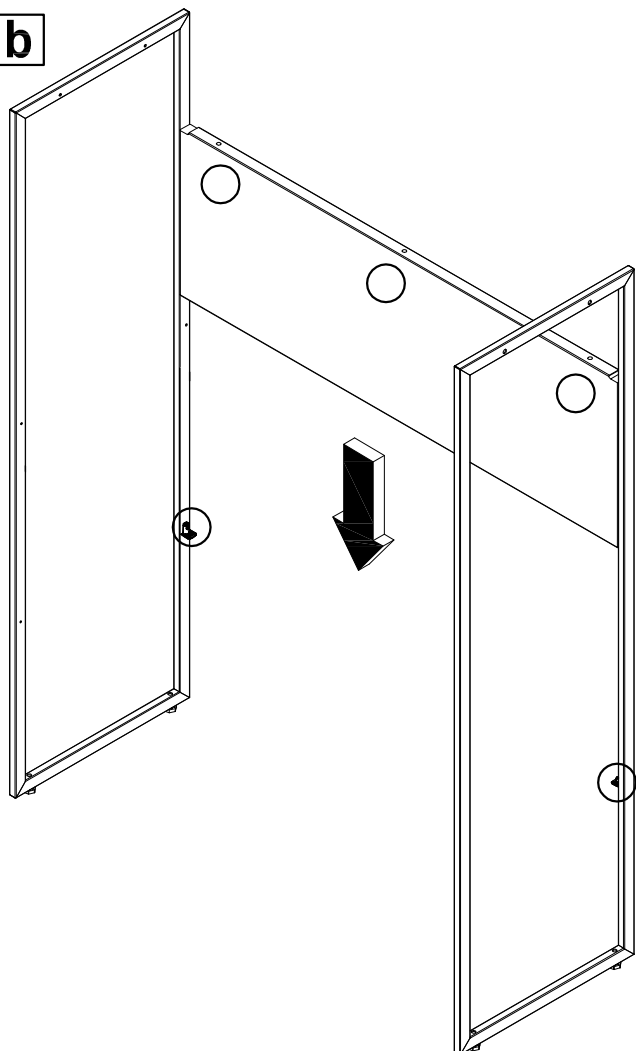

1

BB 2406

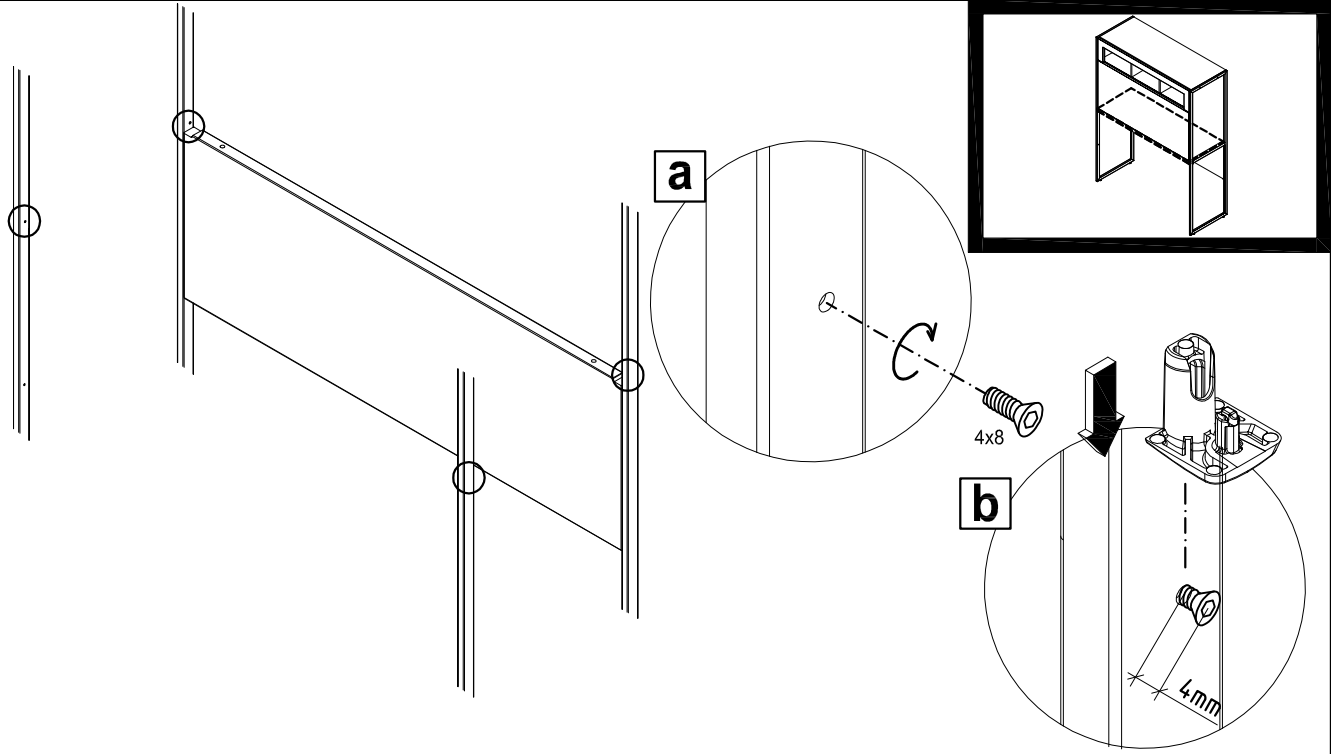

2

BB 809

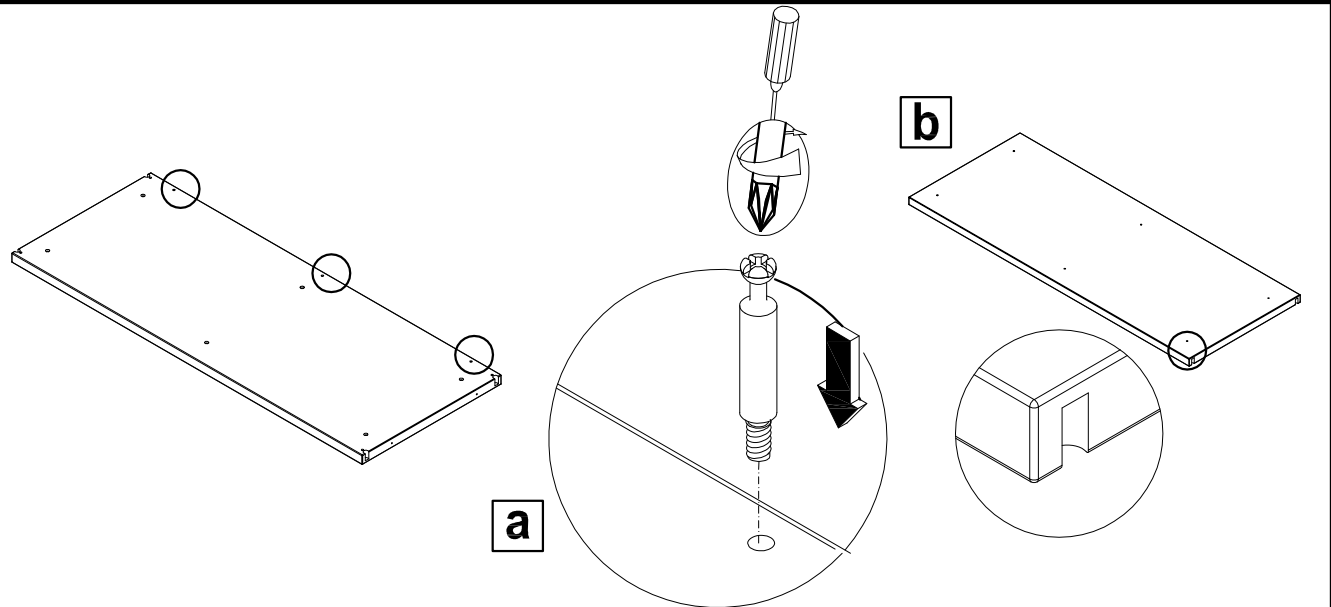

2

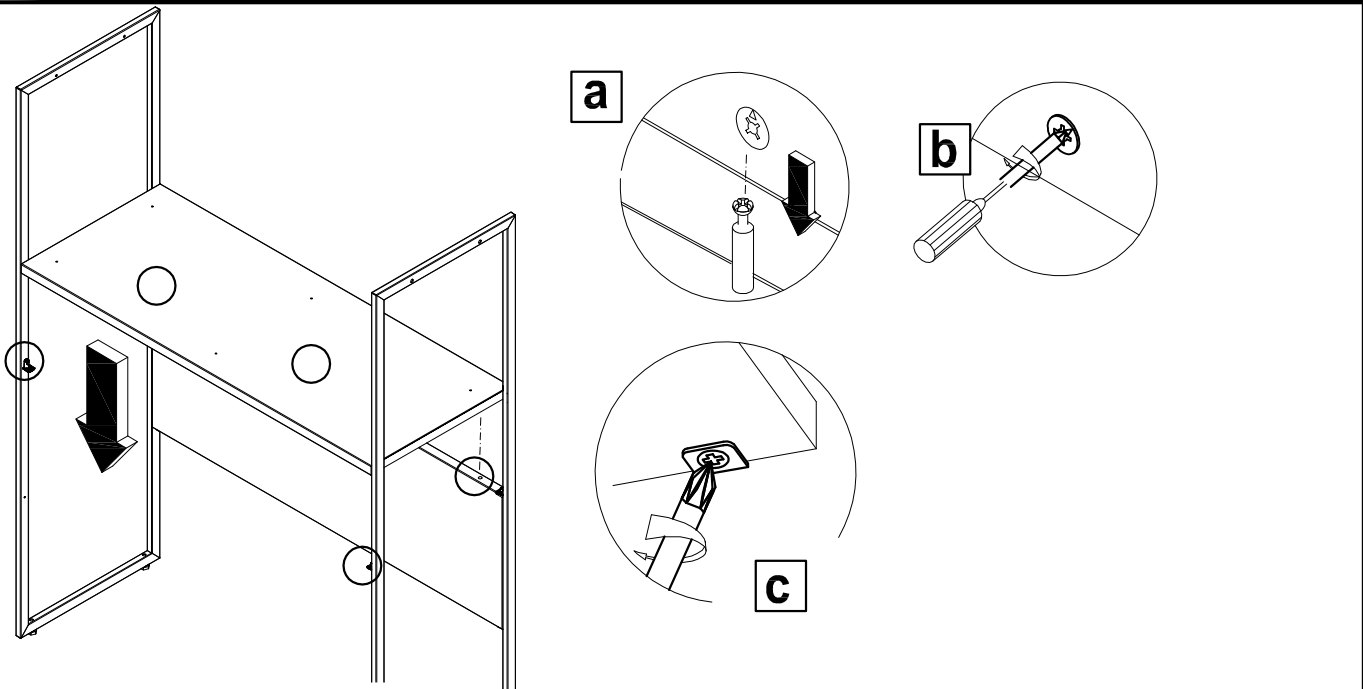

1

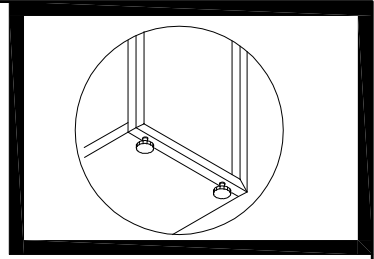
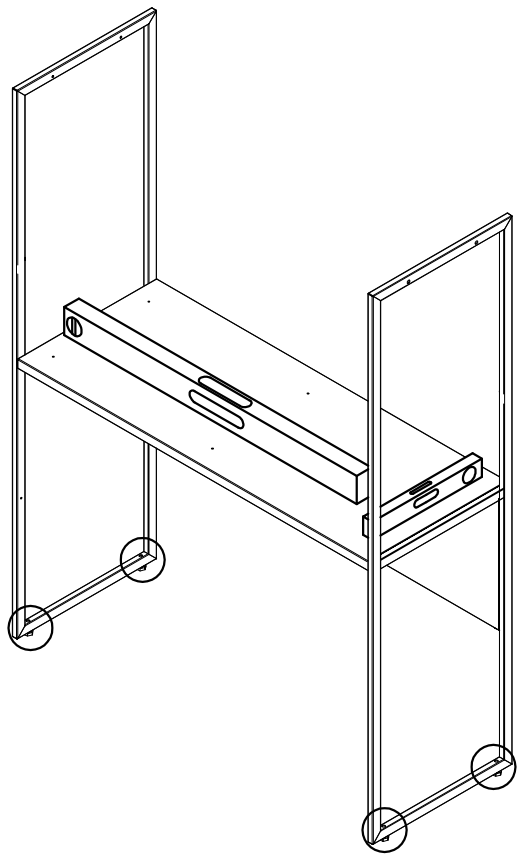

a

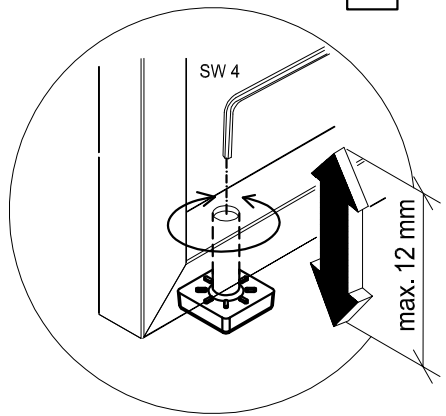

1

BB 2387

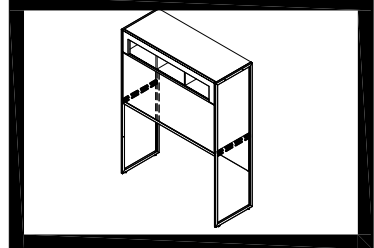
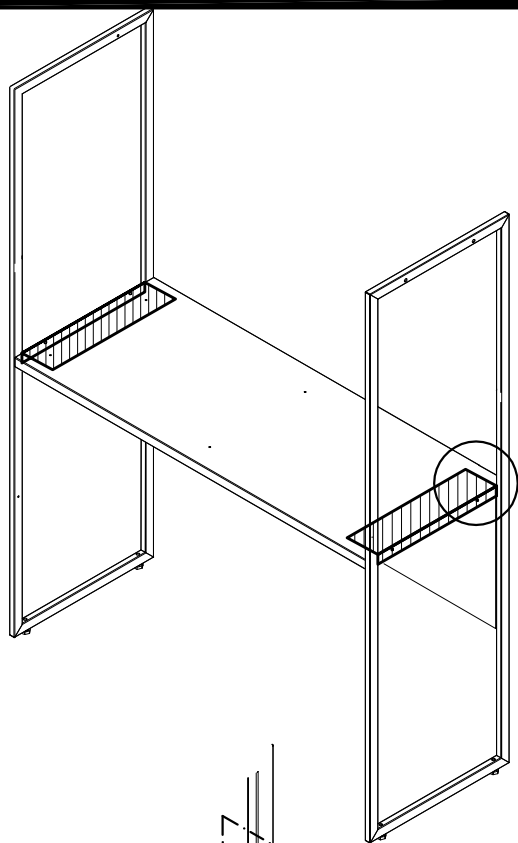

a

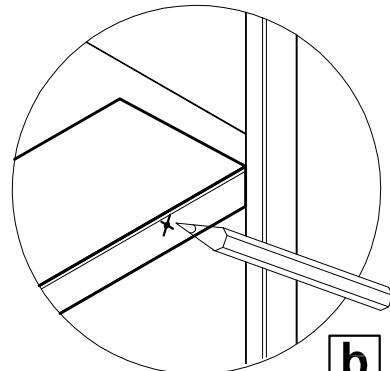

b

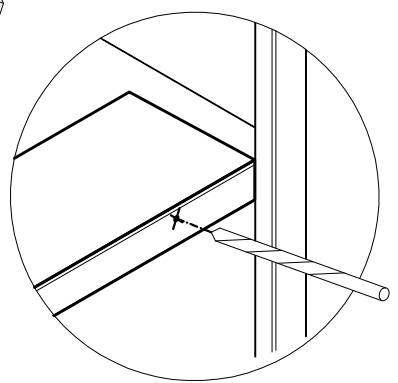

c

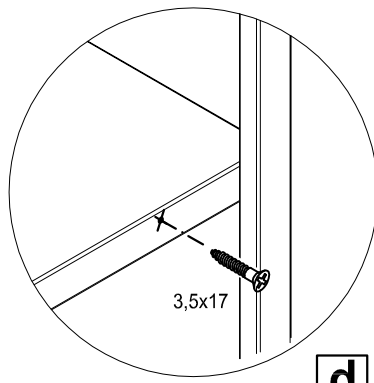

d

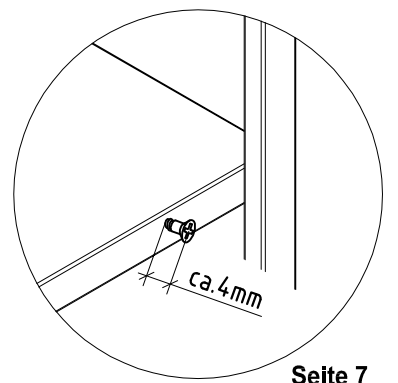

e

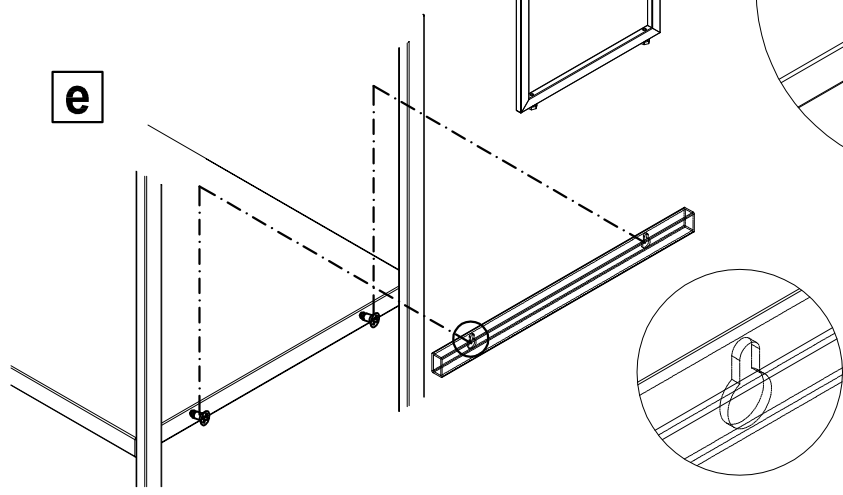

1

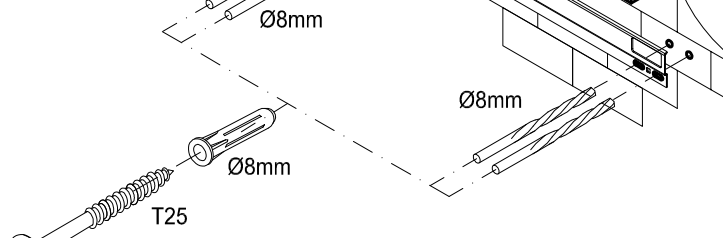
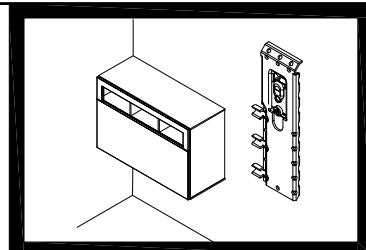
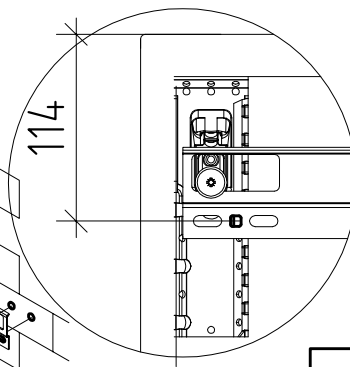
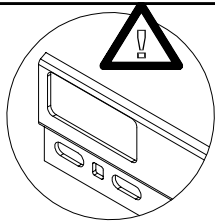

Befestigung mit Ankerhülse
Assembly with anchor sleeve
Montage avec manchon d'ancrage
montage met ankerhulzen
Монтаж с анкерной втулкой
使用轴套安装

Befestigung ohne Ankerhülse
Assembly without anchor sleeve
Montage sans manchon d'ancrage
Montage zonder ankerhulzen
Монтаж без анкерной втулки
不使用轴套安装

Wandbefestigung 6x70

Achtung! Die Wandbeschaffenheit ist vor der Montage unbedingt zu prüfen. Verwendung von Dübeln bei Beton und/oder festem Mauerwerk. Bei abweichender Beschaffenheit (z.B. Rahmenbauweise mit Gipskartonplatten, Leichtbausteinen etc.) ist eine andere, der Belastung angemessene Befestigung bauseits vorzunehmen. Beachten Sie, dass in dem Befestigungsbereich keine Elektro-Installationszonen und keine Ver- oder Entsorgungsleitungen vorhanden sein dürfen. Prüfen Sie mit einem geeigneten Leitungssuchgerät. Beachten Sie, dass Kunststoffrohre nicht dedektiert werden.

Wall mounting

Please note! Please be sure to test the soundness of walls beforehand. Use plugs for concrete and solid walls. Use a different method that is capable of withstanding the load for lighter types of walls (e.g. framed gypsum plaster board, light brickwork, etc.). Please note that there must not be any electrical installations nor any electrical connections or leads of any kind in the assembly area. Please ensure this is so by testing the area with a suitable electrical leads search device. Please also note that plastic tubing will not be detected.

Fixation murale

Attention! La composition du mur doit absolument être contrôlée. Utilisation de chevilles pour le béton et/ou la maçonnerie dure. Pour les autres types de construction (cloisons en placoplâtre, maçonnerie légère, etc...), il faut prévoir un autre mode de fixation en rapport avec la charge. Veuillez contrôler l'absence d'installations électriques et de conduits dans le secteur de la fixation à l'aide d'un appareil. Veuillez noter que les tubes en matière synthétique ne sont pas détectés.

Bevestiging aan de muur

Attentie! Controleer, alvorens te beginnen, altijd de aard en de kwaliteit van de muur, waaraan gemonteerd moet worden. Gebruik voor de bevestiging aan beton en schoon metselwerk de door hülsta meegeleverde standaard pluggen en passende schroeven. In geval van muren van een ander, lichter soort materiaal (bijv. gipsplaten op een raamwerk of lichte bouwstenen) moet een ander, aan het draagvermogen aangepast speciaal bevestigingsmateriaal gebruikt worden. N.B.! In het muurgedeelte waar gemonteerd moet worden, mogen zich geen elektro-installatiezones bevinden resp. mogen geen aan- en/of afvoerleidingen (buizen) lopen. Dit kan gecontroleerd worden met speciale daarvoor bestemde detectieapparatuur. N.B.! Kunststoffleidingen kunnen helaas niet worden gedetecteerd.

壁挂式安装

请注意! 请务必确保提前测试墙壁的稳固性。使用混凝土和实心墙壁插座。对于承重负荷较轻类型的墙壁(例如, 框架结构用石膏板, 轻质砖等), 使用不同的方法找到合理承重点。请注意, 在装配区不能有任何电气设施, 也不能有任何电气连接装置或任何类型的导线。请确保(此注意事项)在装配区经由相应的电引搜索设备进行了搜索检测。同时请注意, 塑料管是无法被(此搜索设备)检测到的。

Настенное крепление

Пожалуйста, обратите внимание! Не забудьте проверить надежность стен заранее. Используйте заглушки для бетонных и монолитных стен. Используйте другой метод, который способен выдерживать нагрузку для более легких типов стен (например, для гипсокартона и для легкой кирпичной кладки и т.д.). Обратите внимание, что не должно быть каких-либо электрических проводов, ни каких-либо электрических соединений в месте крепления. Пожалуйста, убедитесь, что это так, путем тестирования данной области подходящим поисковым устройством (тестером). Обратите внимание, что пластиковые трубки не обнаруживаются.

1

Befestigung mit Ankerhülse
Assembly with anchor sleeve
Montage avec manchon d'ancrage
montage met ankerhulzen
Монтаж с анкерной втулкой
使用轴套安装

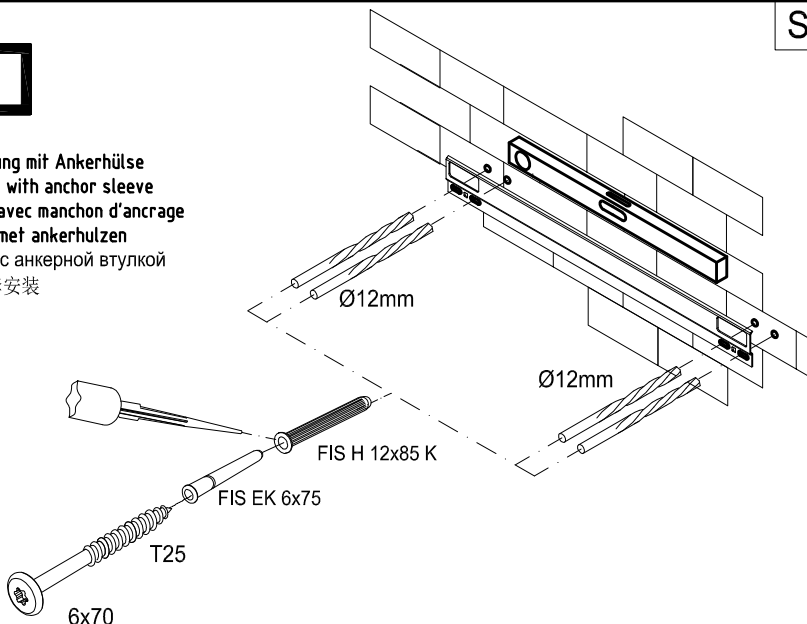

SET

Mat. 1535747

9x		FIS H 12x85 K
9x		FIS EK 6x75
1x		
2x		

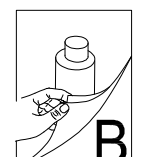
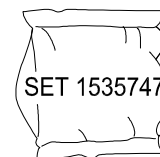

Mat. Nr. 1537293

1

Befestigung ohne Ankerhülse
Assembly without anchor sleeve
Montage sans manchon d'ancrage
Montage zonder ankerhulzen
Монтаж без анкерной втулки
不使用轴套安装

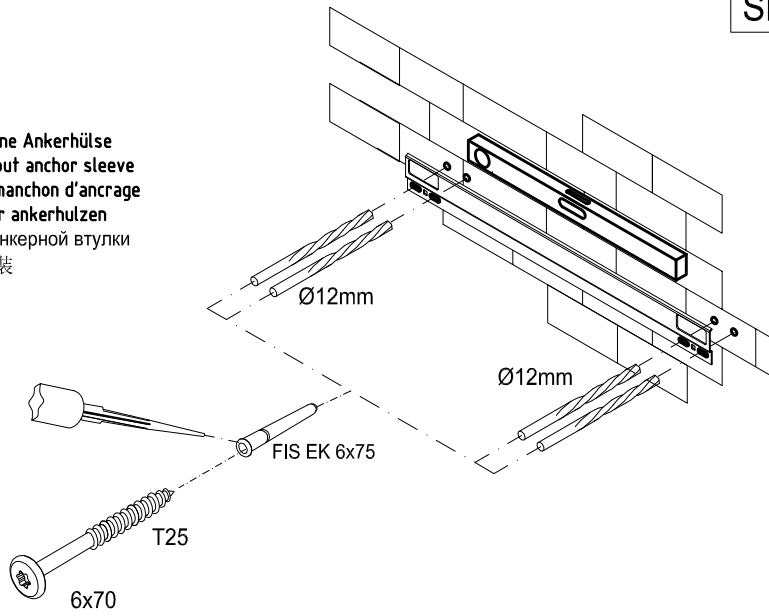

SET

Mat. 1535747

9x		FIS H 12x85 K
9x		FIS EK 6x75
1x		
2x		

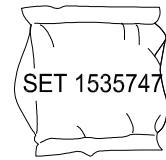

Mat. Nr. 1537293

(2a)

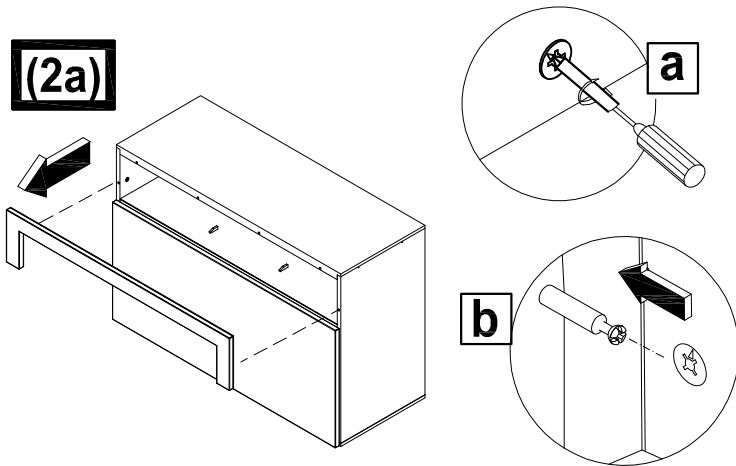

(2b)

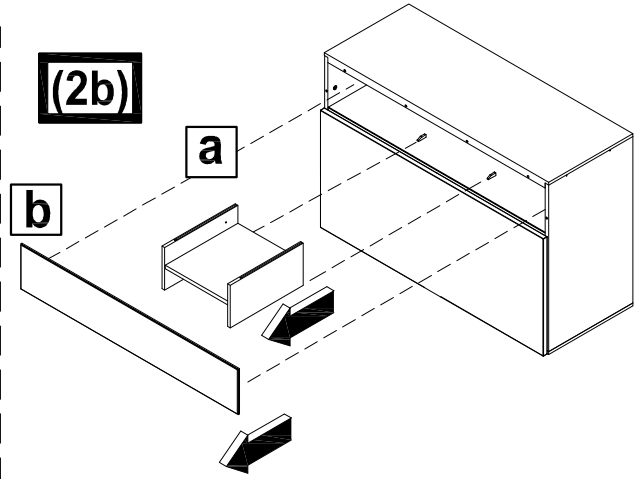

2

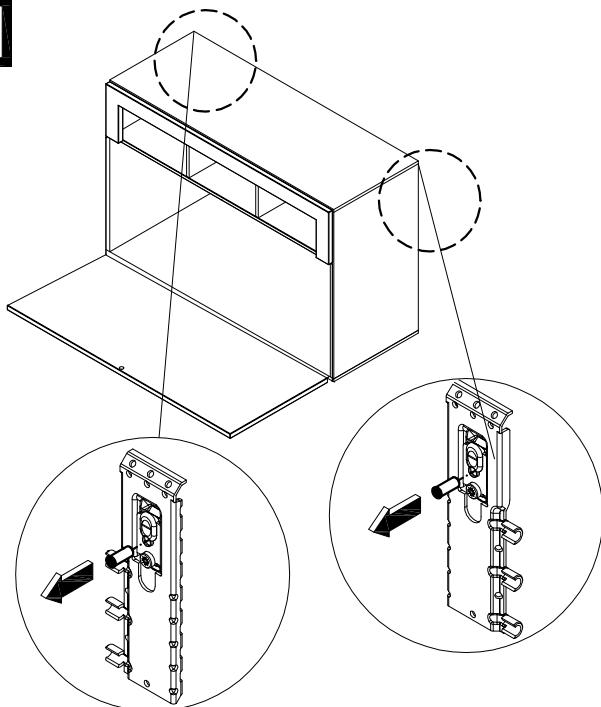

3

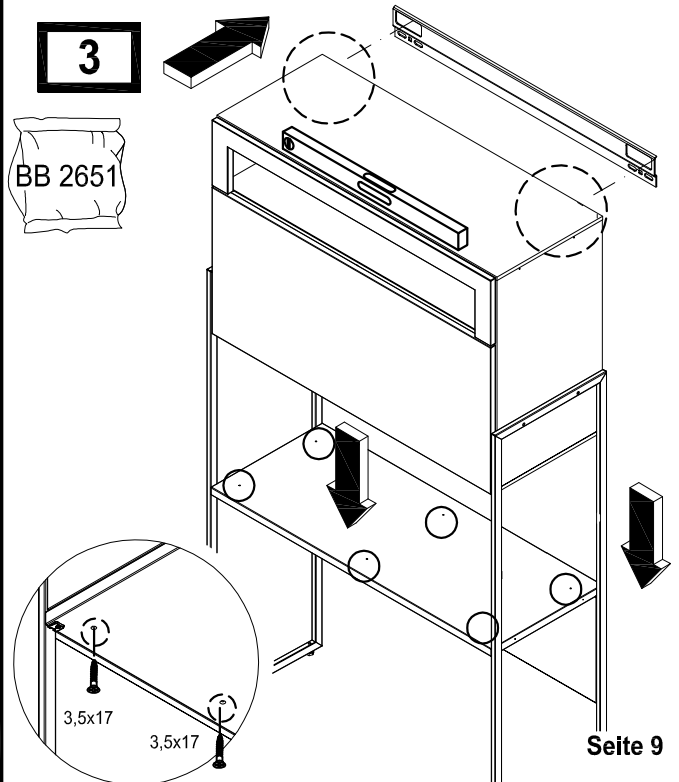

Seite 9

4

BB 2743

BB 2166 /
2170 /
2714

BB 2108

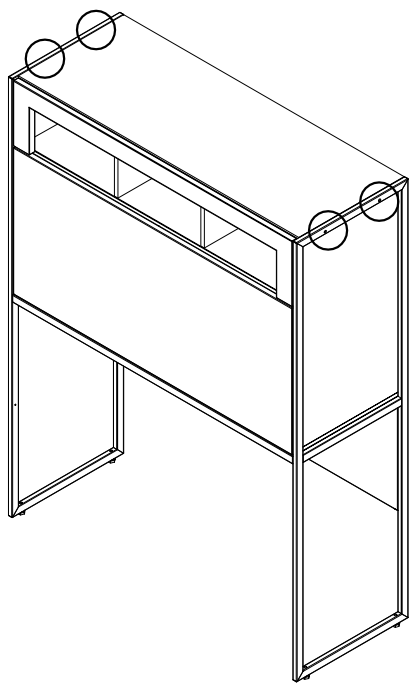

c

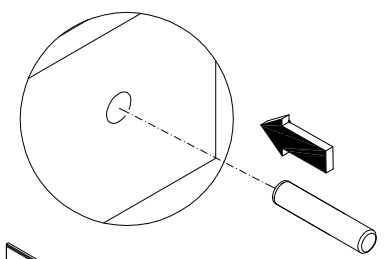
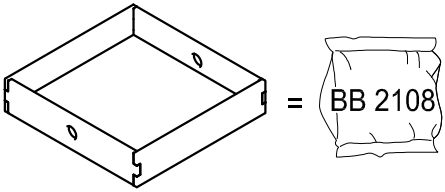

a

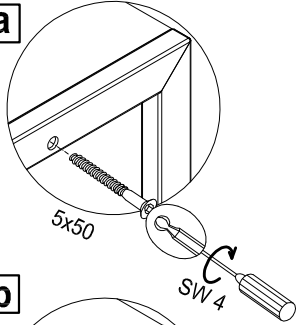

b

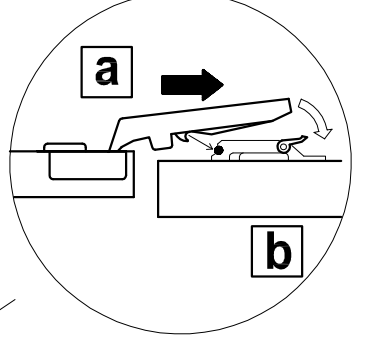
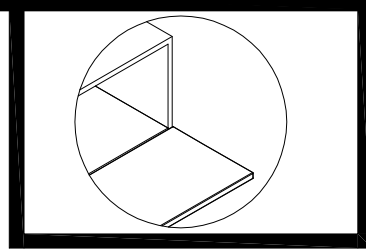
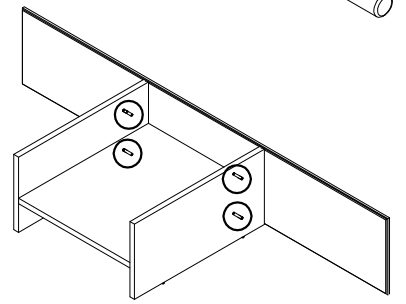
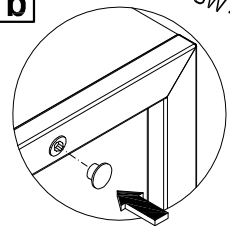

1

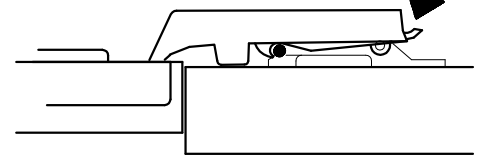
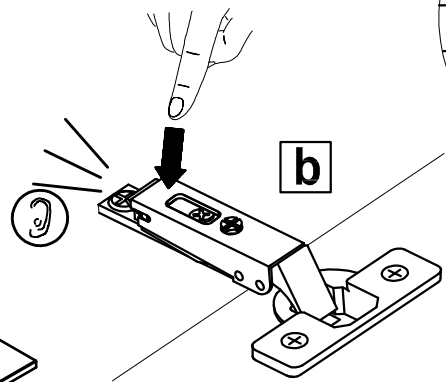
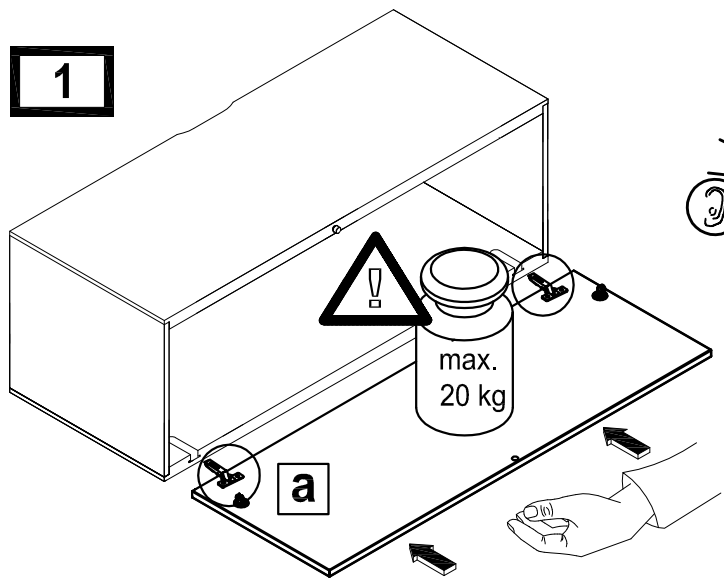

2

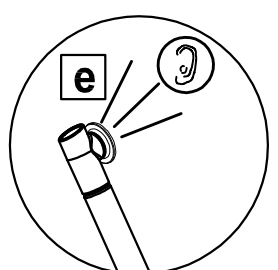
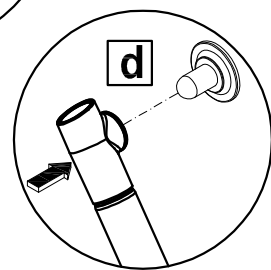
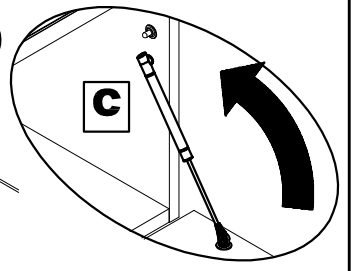
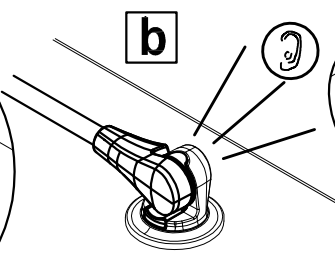
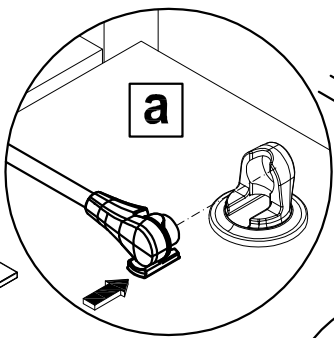
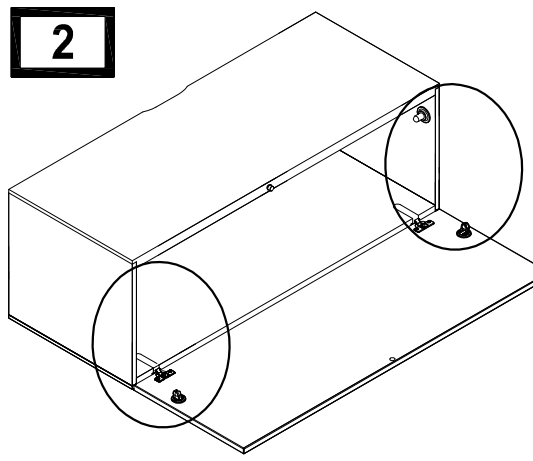

3

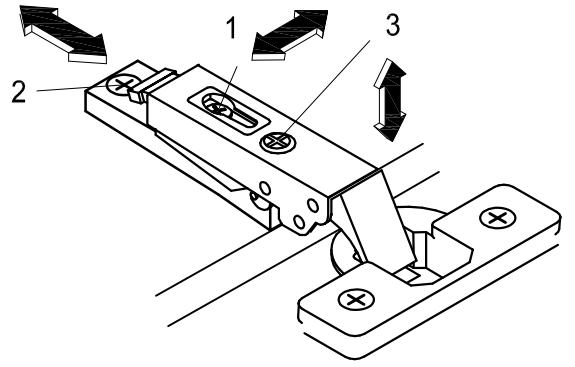
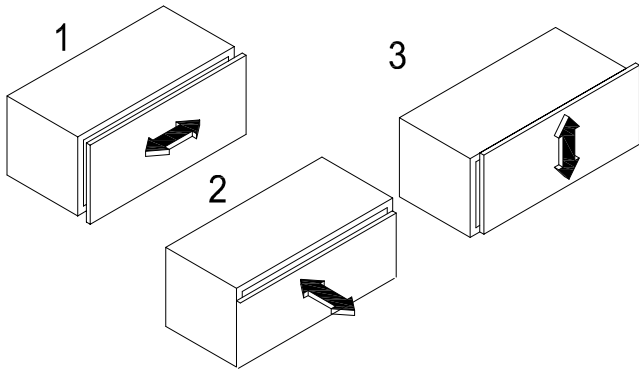

4

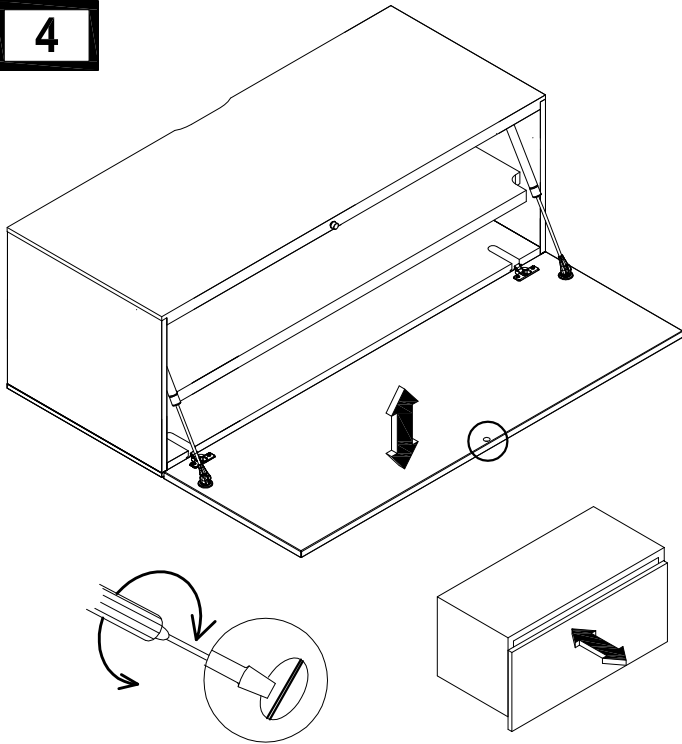

5

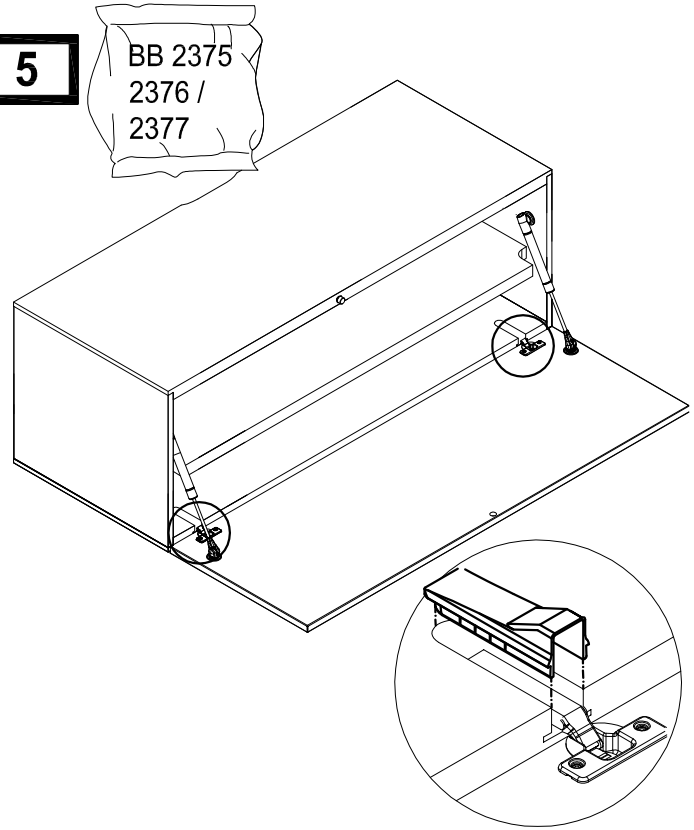

1

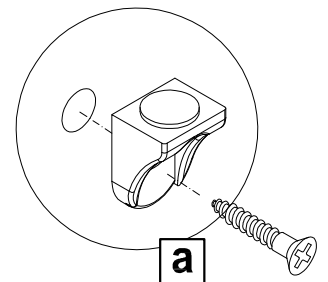
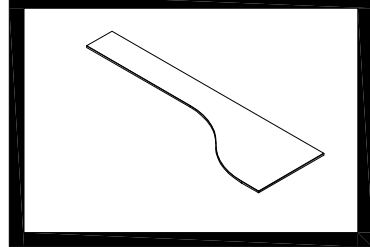
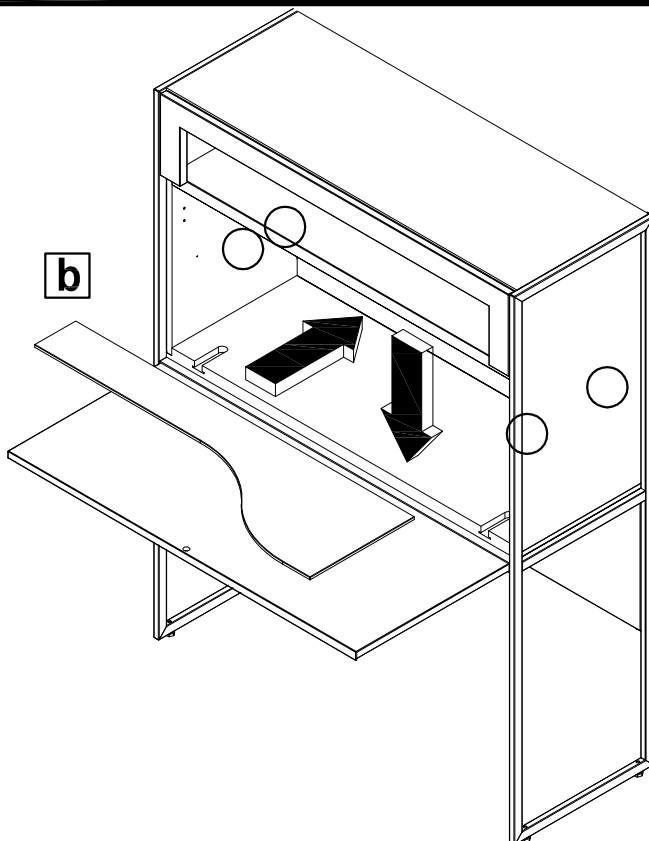

3,5x15