

# now wardrobe

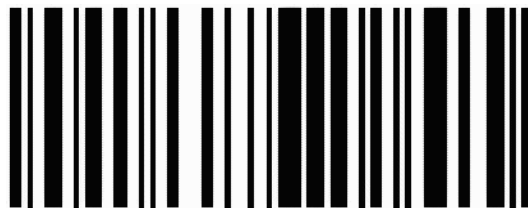
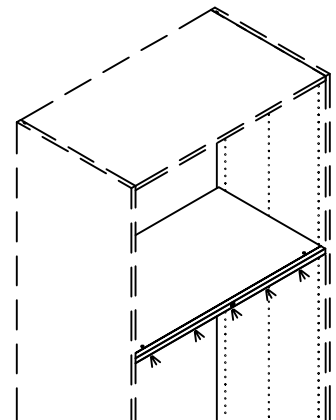
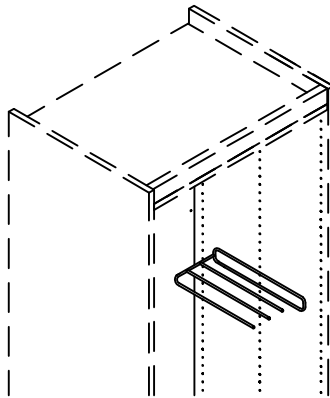
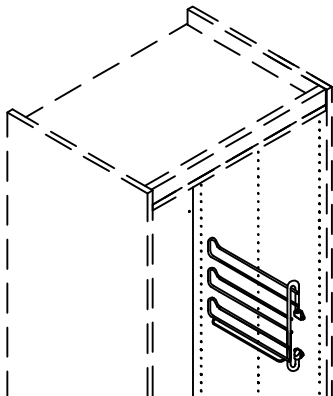
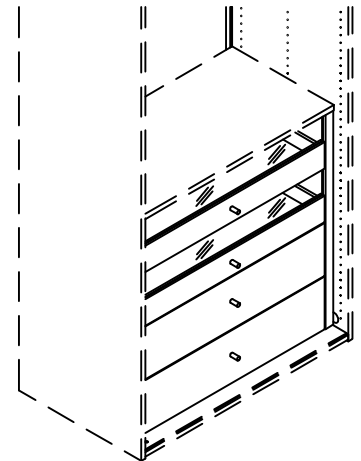
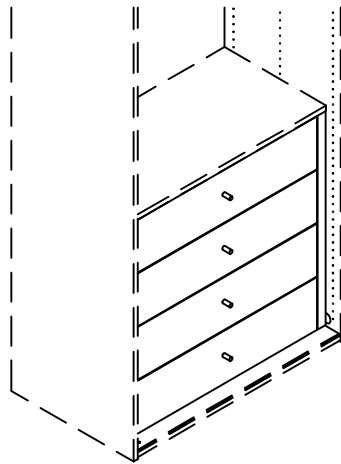
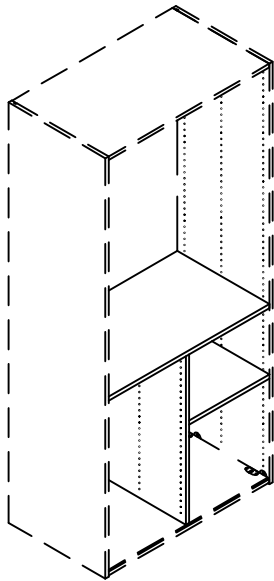

1563109

## Inhalt:

### **Wäsche- und Zwischenboden Mittelseite**

**3-8**

Linen and intermediate shelf / partition \* *Tablette à linge et plateau intermédiaire / cloison*

Linnengoed- en tussenplank / tussenschot

### **Schubladen-Sets und Auszüge**

**9-16**

Sets of drawers and pull-out units \* *Sets de tiroirs et plateaux coulissants* \* Laden-sets en uitschuifbladen

### **LED-Lichteinlegeboden**

**17-22**

LED illuminated shelf \* *Tablette lumineuse LED* \* LED-lichtplank

### **Krawattenhalter**

**23**

Tie holder \* *Support cravates* \* Stropdassenhouder

### **Hosenhalter**

**24-25**

Trouser holder \* *Support pantalons* \* Pantalonhouder

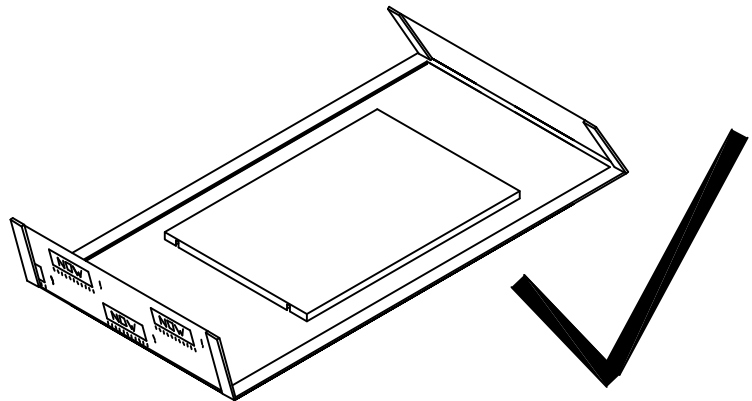
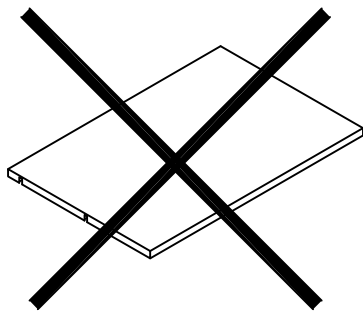
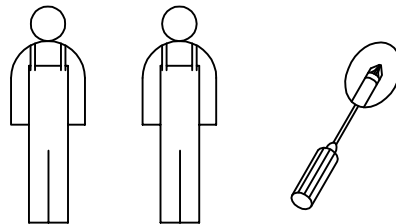

### **Verehrter Kunde, hier haben Sie die Möglichkeit die mitgelieferten Schrauben nachzumessen.**

Dear customer, here you can find a way of measuring the screws supplied!

*Cher client, vous avez ici la possibilité de mesurer les vis livrées!*

Beste klant, hier kunt u de meegeleverde schroeven nameten!



**Wäsche- und Zwischenboden / Mittelseite**

Linen and intermediate shelf / partition

*Tablette à linge et plateau intermédiaire / cloison*

Linnengoed- en tussenplank / tussenschot

**Beispiele:**



Examples:

*Exemples:*

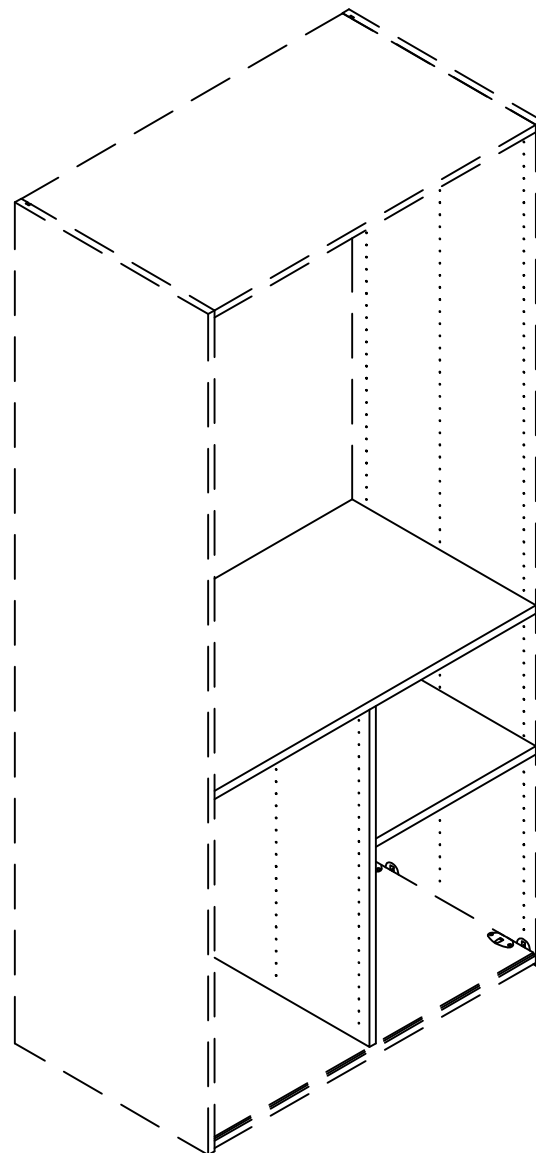
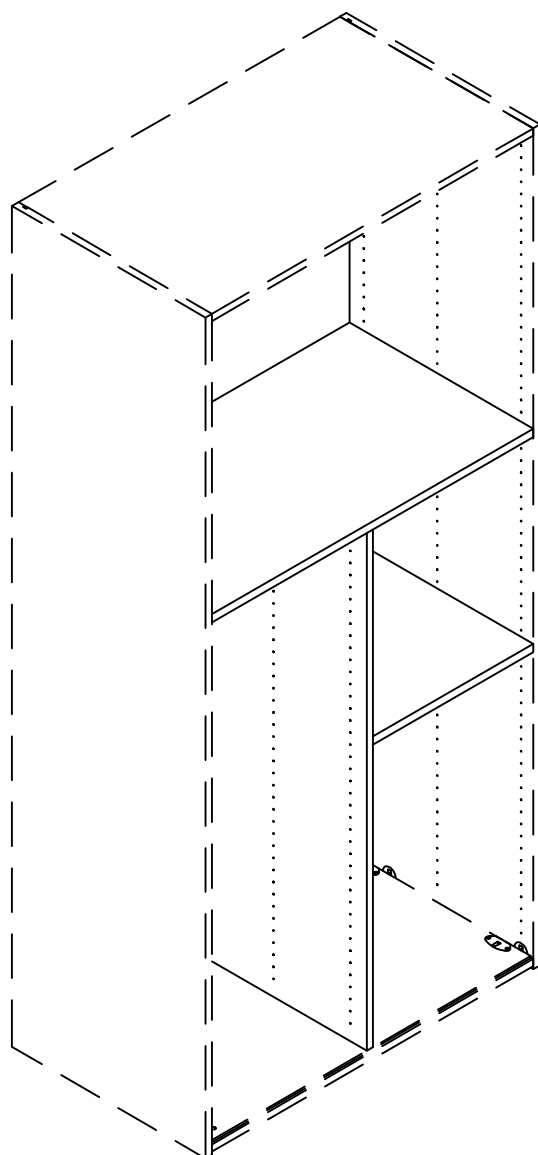
Voorbeelden:

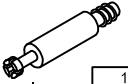

**BB 2331**  
Mat.-Nr.: 1550677

<b>B</b>		<b>2x</b>
		316995
<b>C</b>		<b>2x</b>
		16154
<b>D</b>		<b>2x</b>
		1504129

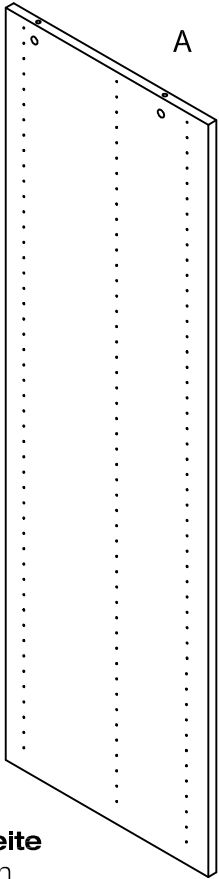

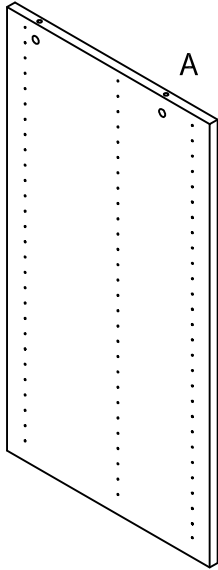

**6R Mittelseite**  
6R partition  
*Cloison 6U*  
6R tussenschot



**4R Mittelseite**  
4R partition  
*Cloison 4U*  
4R tussenschot

**BB 1023**  
Mat.-Nr.: 1026823

<b>H</b>		<b>4x</b>
		500708
<b>J</b>		<b>4x</b>
		4x15 936774

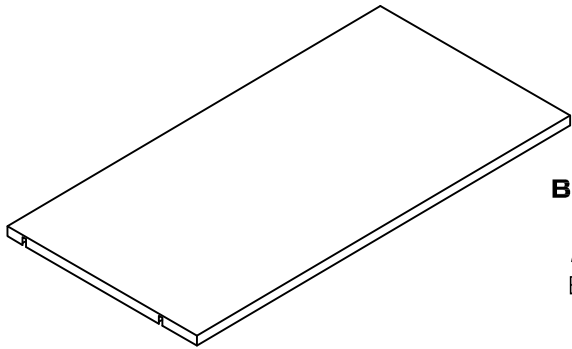

**F**  
**Breite = 78 / 98 / 118 cm**  
Width = 78 / 98 / 118 cm  
Largeur = 78 / 98 / 118 cm  
Breedte = 78 / 98 / 118 cm

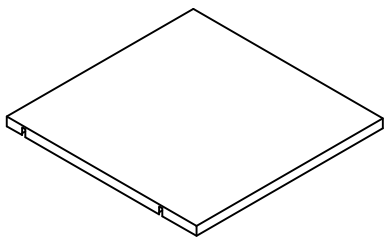

**G**  
**Breite = 38 / 48 cm**  
Width = 38 / 48 cm  
Largeur = 38 / 48 cm  
Breedte = 38 / 48 cm



**Achtung:**

**Bitte beachten Sie die bei der Bestellung angegebene Innenausstattung.  
Bitte wählen Sie die Position(en) der Mittelseite(n) entsprechend der bestellten Innenausstattung mit Schubladen-Sets, Auszügen und Zwischenböden.**

Caution:

Please remember the stated interior fittings when ordering.

Please select the position(s) of the partition(s) in line with the interior fittings ordered with sets of drawers, pull-out units and intermediate shelves.

Attention:

*Veillez respecter l'aménagement intérieur mentionné sur la commande.*

*Veillez choisir la ou les positions de la ou des cloisons en rapport avec l'aménagement intérieur commandé composé de sets de tiroirs, de plateaux coulissants et de tablettes intermédiaires.*

Attentie:

Let op de bij de bestelling aangegeven kastinrichting.

Kies de positie(s) van de tussenschot(ten) overeenkomstig met de bestelde kastinrichting met laden-sets, uitschuifbladen en tussenplanken.

1

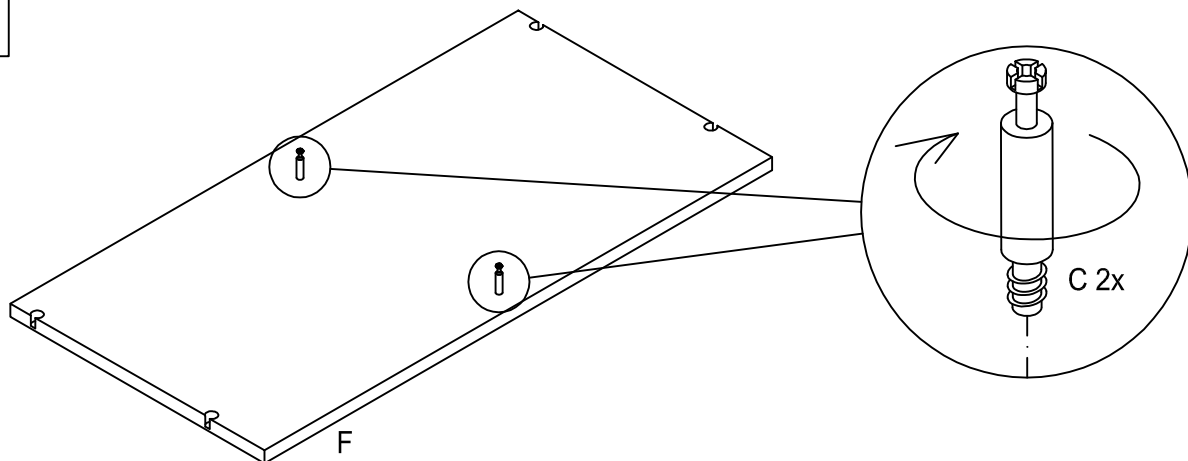

2

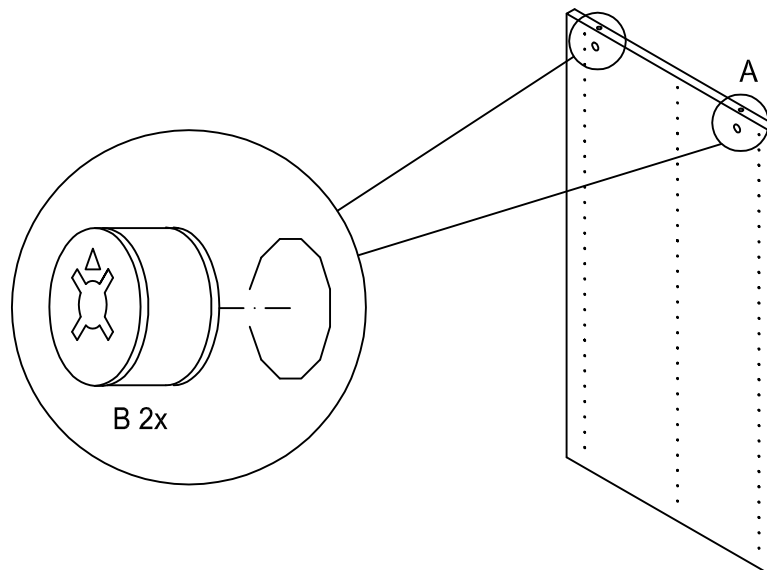

**Markierungspfeil muß zur Bohrung in der Bauteilkante zeigen!**

Arrow on cam must point to hole in the edge of the panel!

*La flèche doit être orientée vers le perçage de l'élément!*

Pijl moet richting de boring in de kopskant wijzen!

3

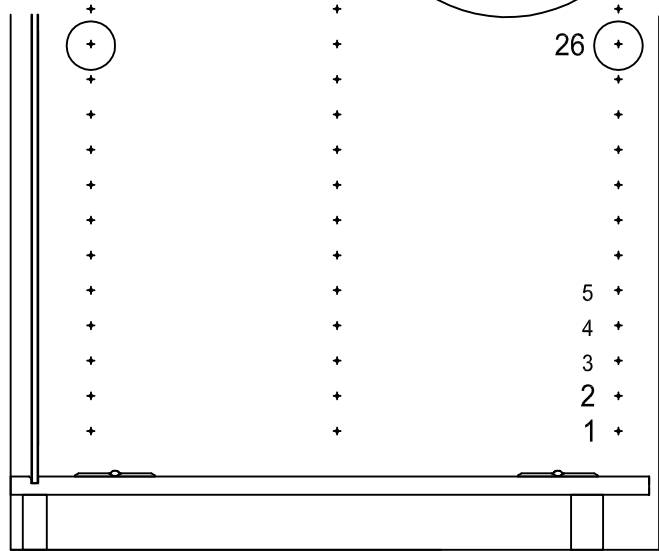
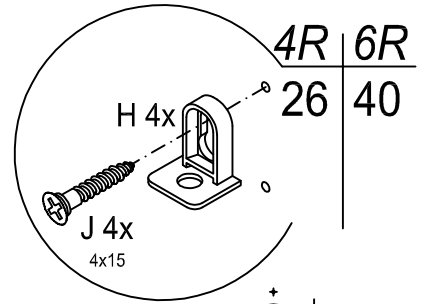
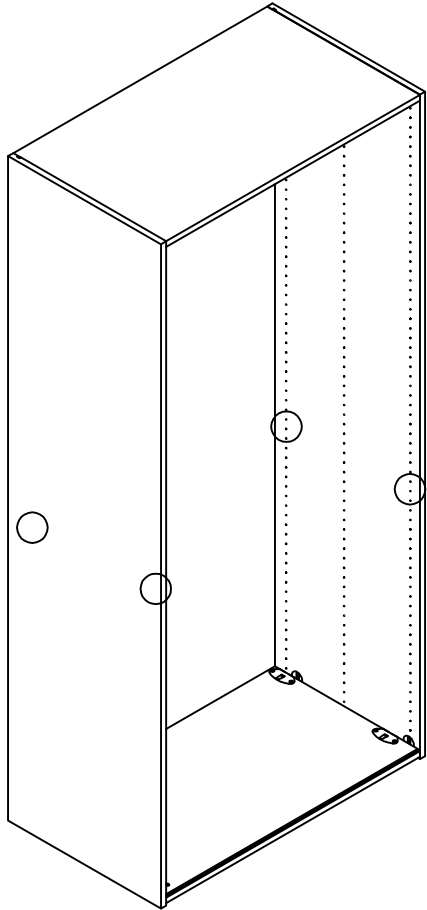

**Zählweise ausgehend vom Sockelboden**

Count from the plinth shelf upwards

*Méthode de calcul en commençant par la tablette de socle*

Tellend uitgaande van het sokkelblad

4

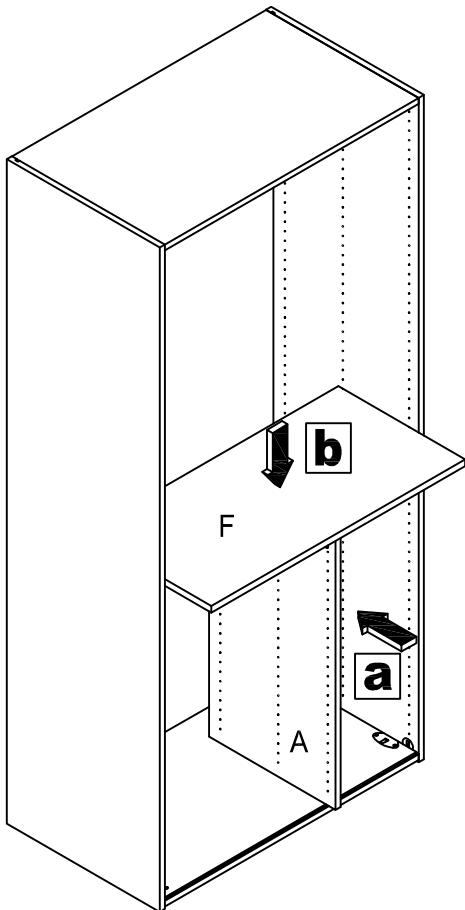

5

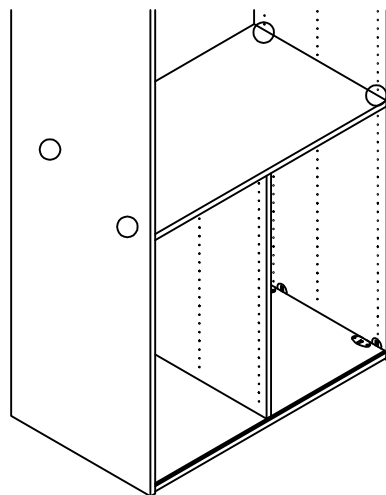

**Bodenverriegelung**

Locking of shelf

*Verrouillage de la tablette*

Plankvergrendeling

6

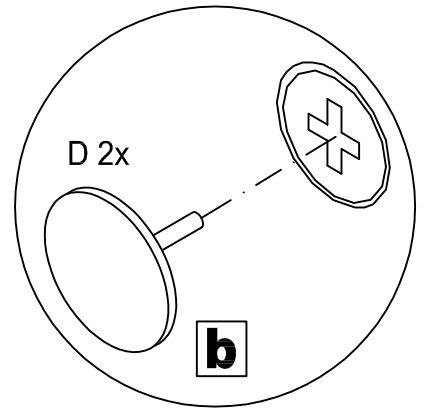
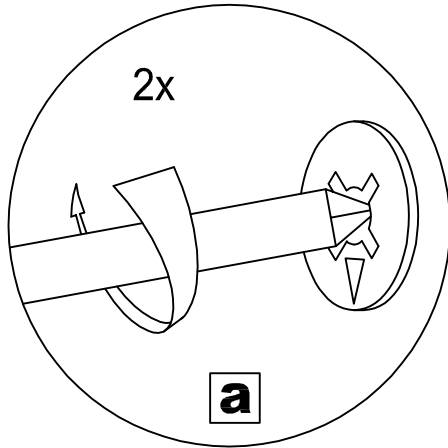
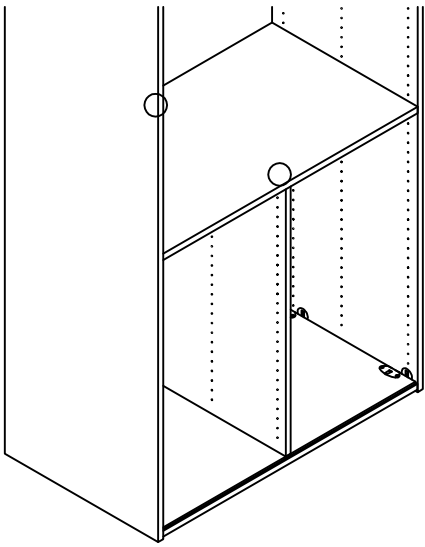

7

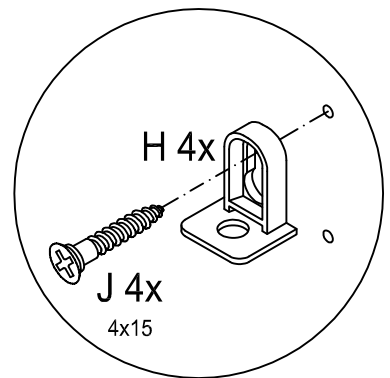
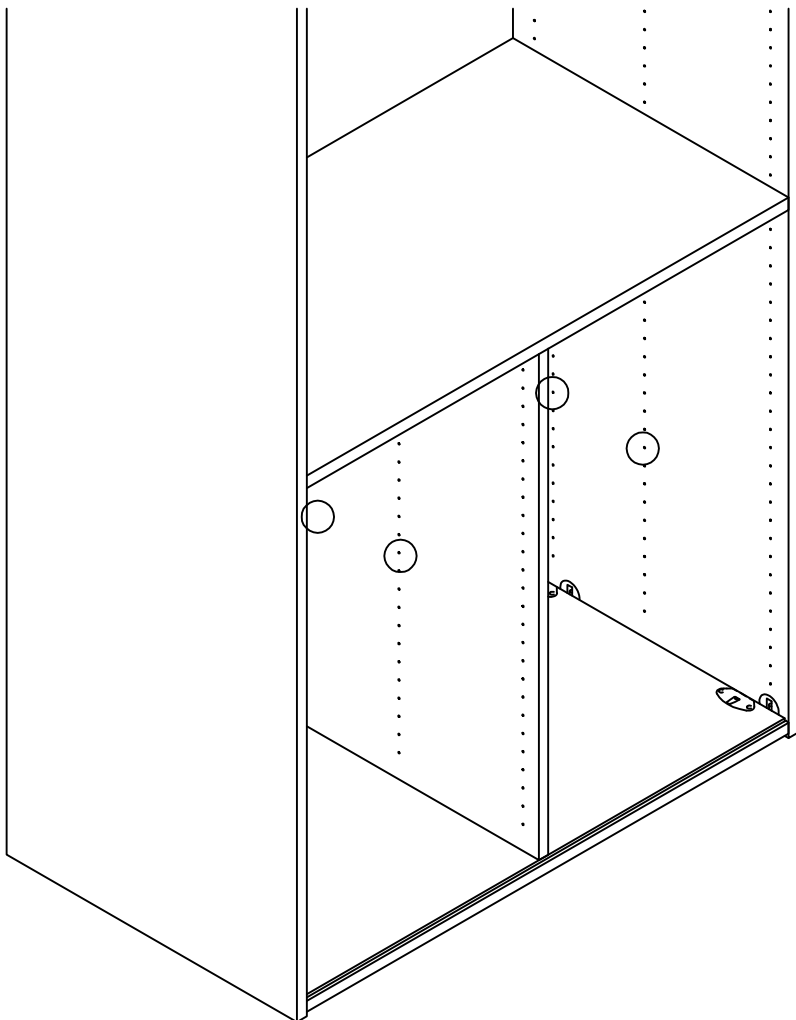

8

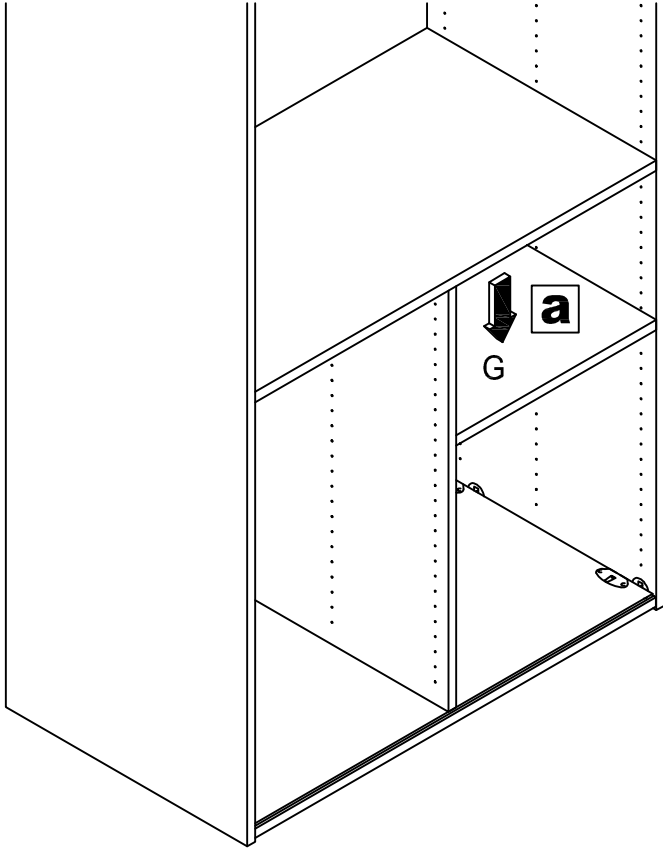



# Schubladen-Sets und Auszüge

Sets of drawers and pull-out units  
Sets de tiroirs et plateaux coulissants  
Laden-sets en uitschuifbladen

## Beispiele:

Exemples:  
Exemples:  
Voorbeelden:

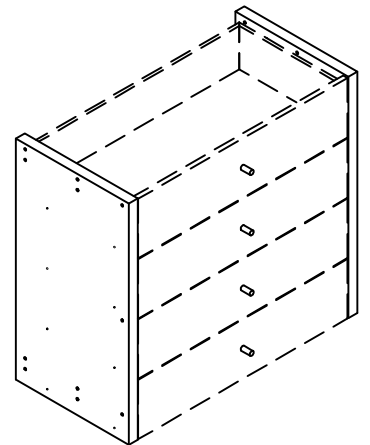
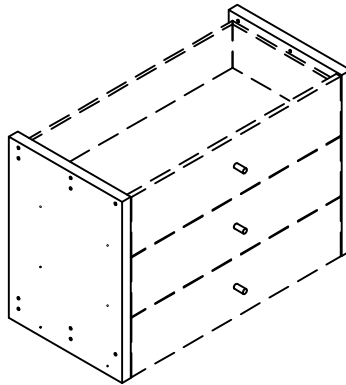
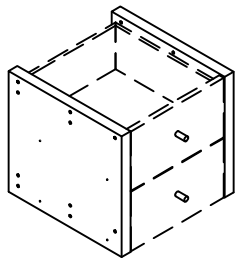
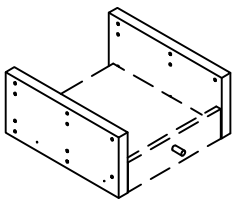
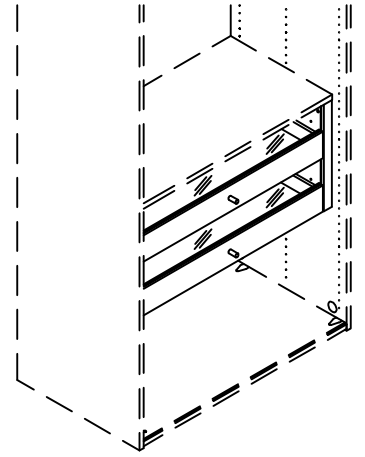
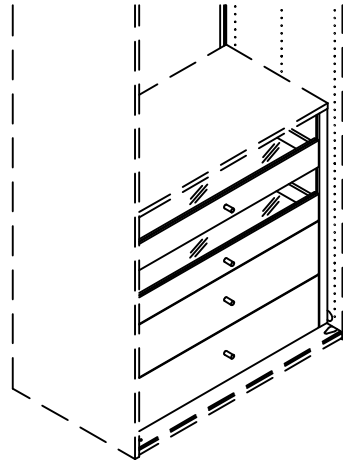
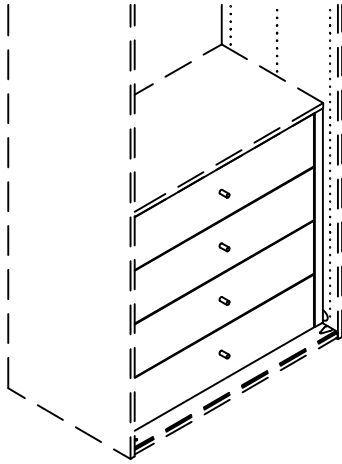

C 2x  
**1R Höhe**  
1R height  
Hauteur de 1u  
1R hoogte

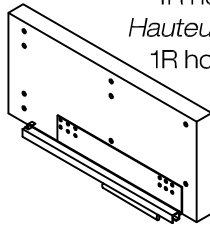

C 2x  
**3R Höhe**  
3R height  
Hauteur de 3u  
3R hoogte

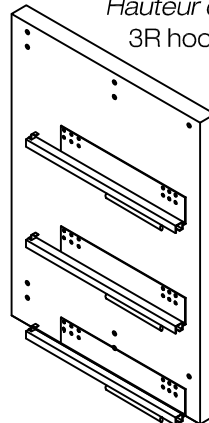

C 2x  
**4R Höhe**  
4R height  
Hauteur de 4u  
4R hoogte

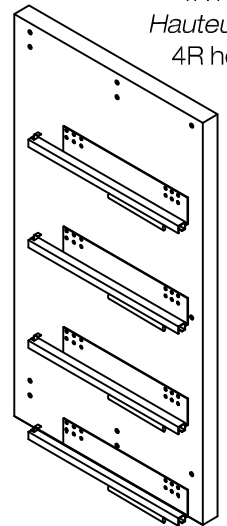

C 2x  
**2R Höhe**  
2R height  
Hauteur de 2u  
2R hoogte

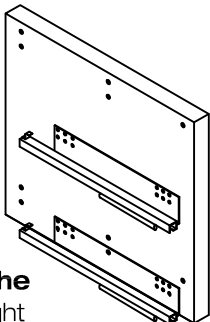

BB 1843

Mat.-Nr.: 1307533

A  14x

4x50

1078851

## Blockseitenmontage

Block side assembly

Montage des faces latérales d'un bloc

Montage van kastinterieurzijden

1

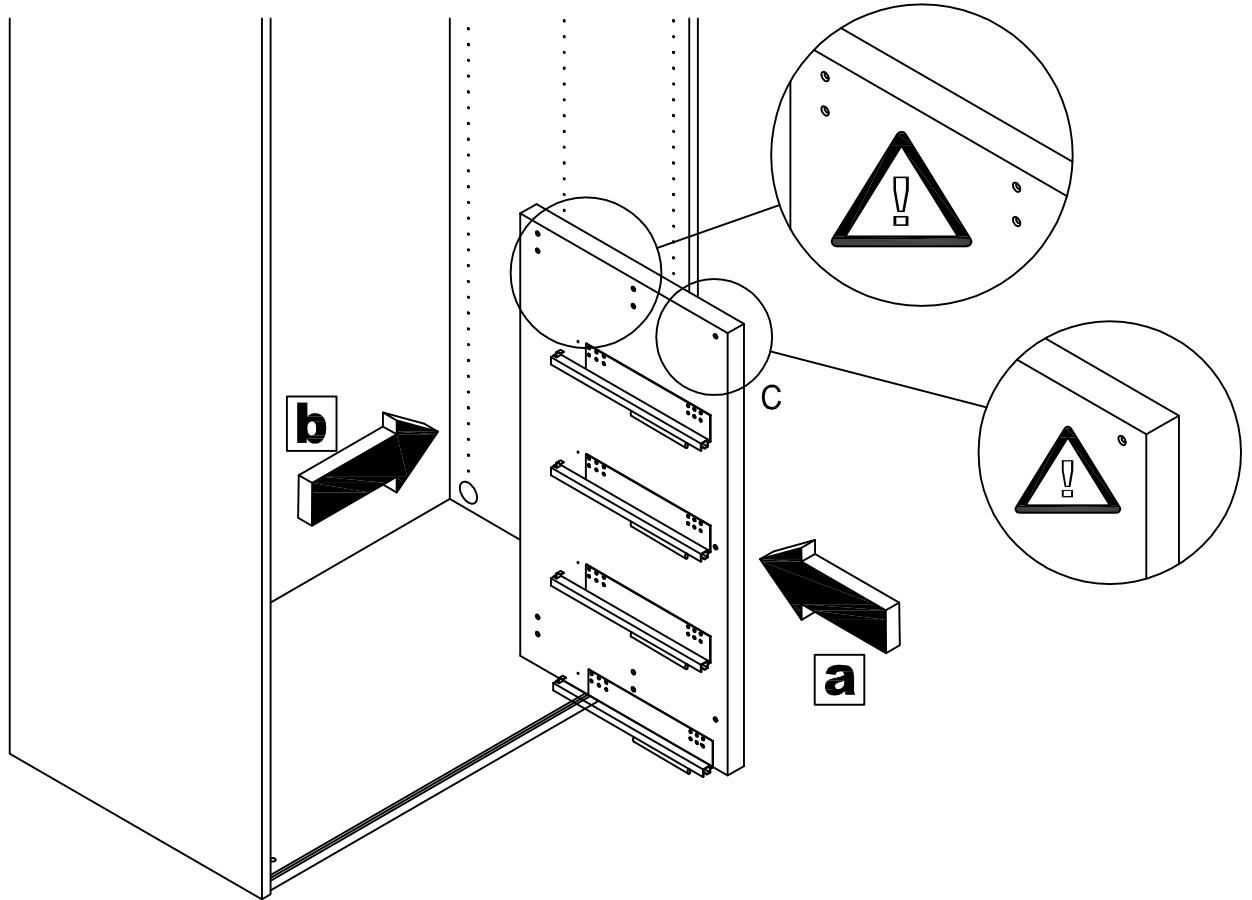

2 1.

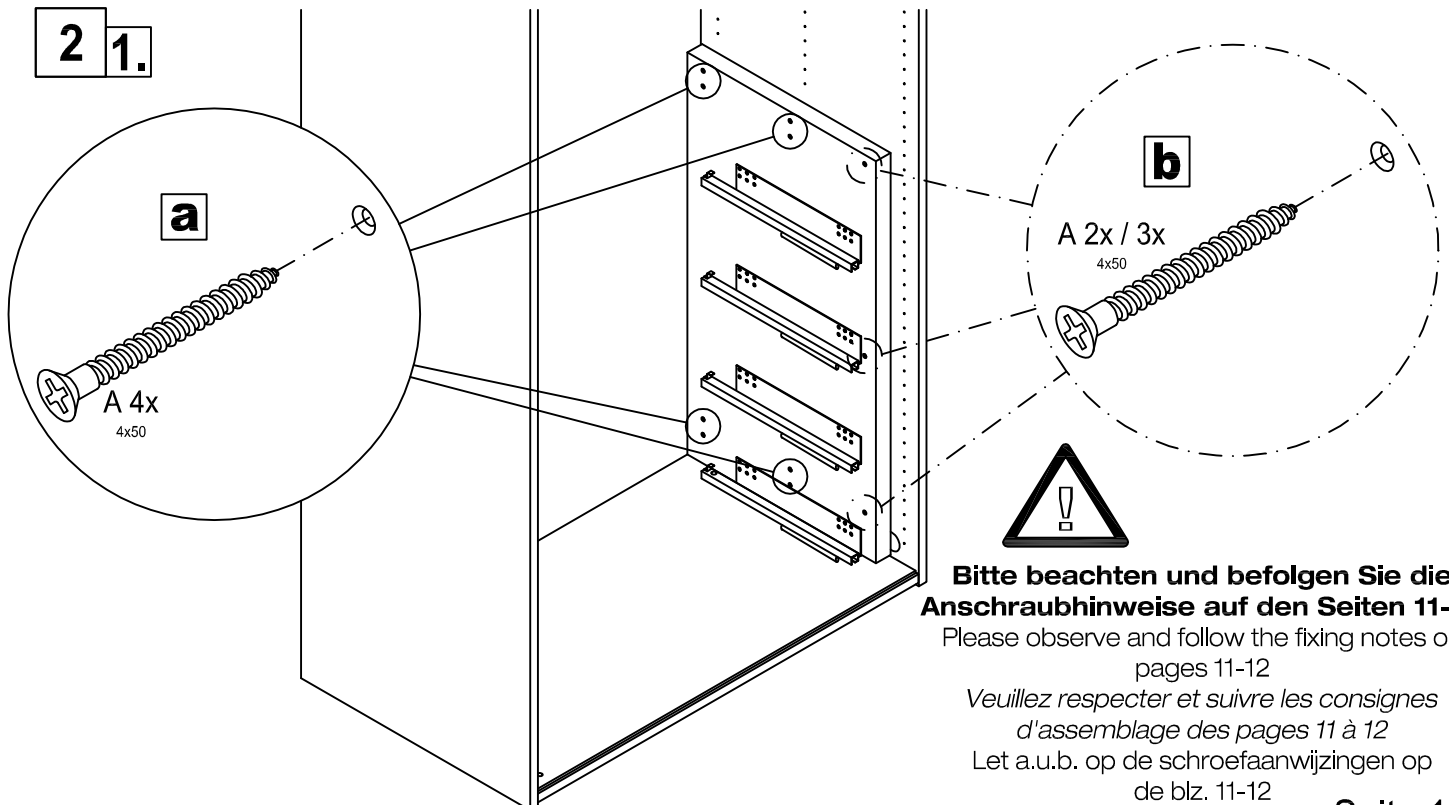

**2** **2.**

**Bitte verwenden Sie folgende Bohrungen zur Befestigung der Seiten bei einer freien Positionierung der Seiten im Kleiderschrank!**

Please use the drills below for fitting the side-panels when they can be positioned anywhere in the wardrobe!  
*Veillez utiliser les perçages suivants pour la fixation des faces latérales lors d'un libre positionnement sur le côté d'une armoire!*

Gebruik a.u.b. de volgende boringen voor het bevestigen van de zijden bij een vrije positionering van de zijden in de klerkast!

1R

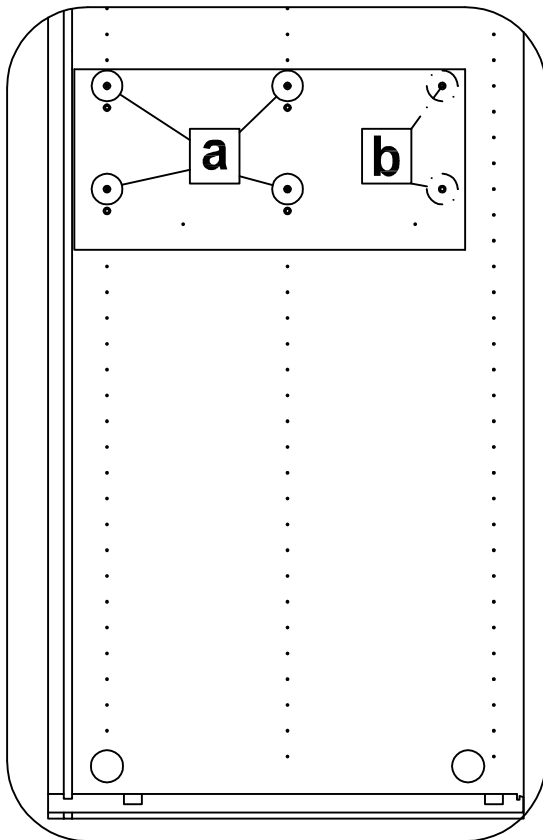

2R

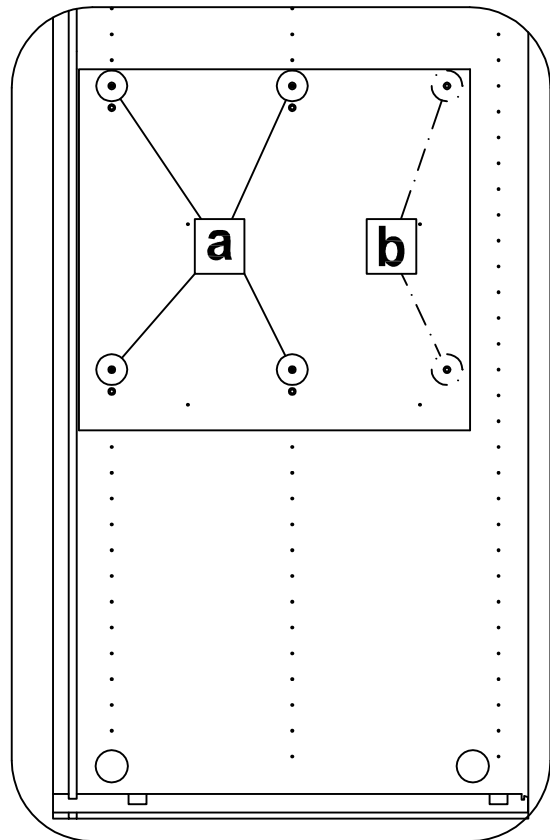

3R

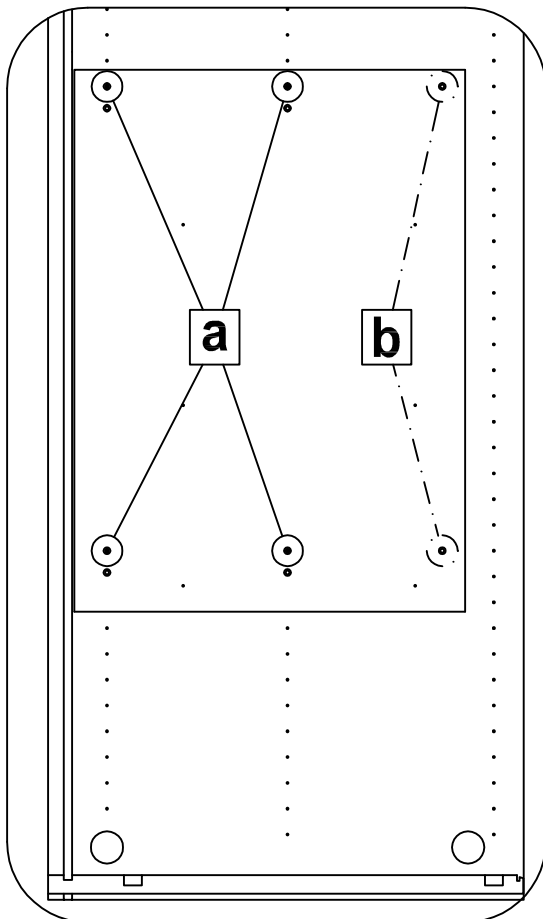

4R

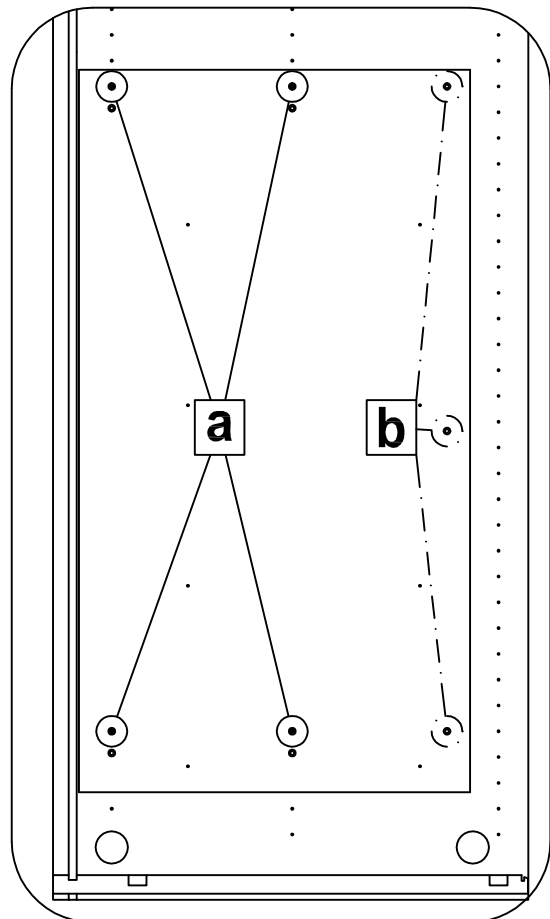

**2** **2.**

**Bitte verwenden Sie folgende Bohrungen zur Befestigung der Seiten (C 2x), wenn diese auf dem Sockelboden aufstehen!**

Please use the drills below for fitting the side-panels (C 2x) when they stand on the plinth shelf!

*Veillez utiliser les perçages suivants pour la fixation des faces latérales (C 2x) lorsque celles-ci doivent reposer sur la tablette de socle!*

Gebruik a.u.b. de volgende boringen voor het bevestigen van de zijden (C 2x), als deze direct op het sokkelblad staan!

1R

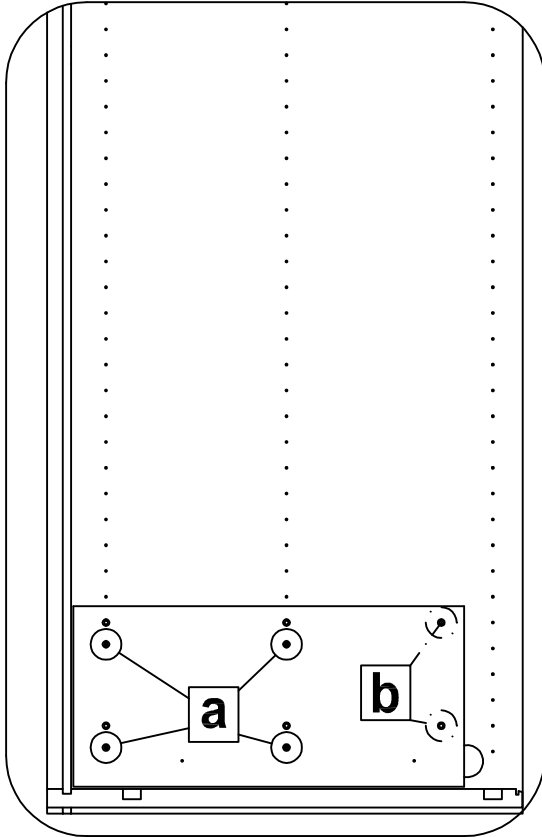

2R

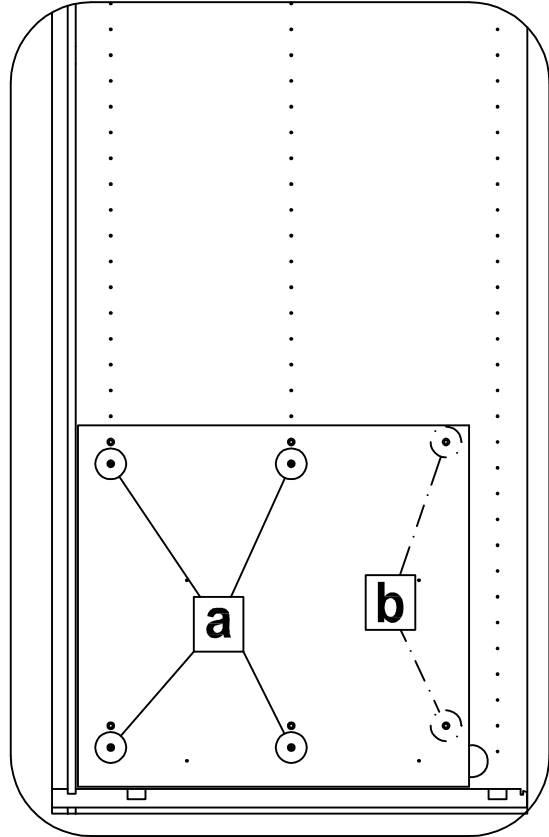

3R

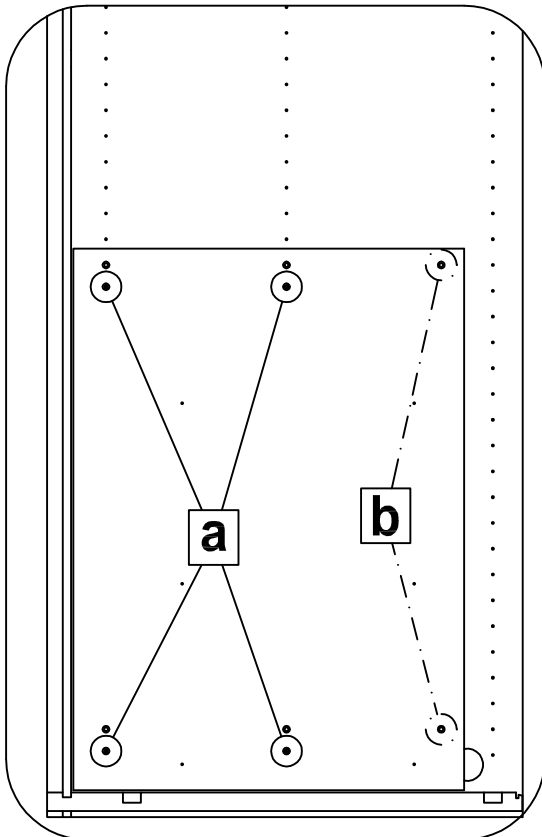

4R

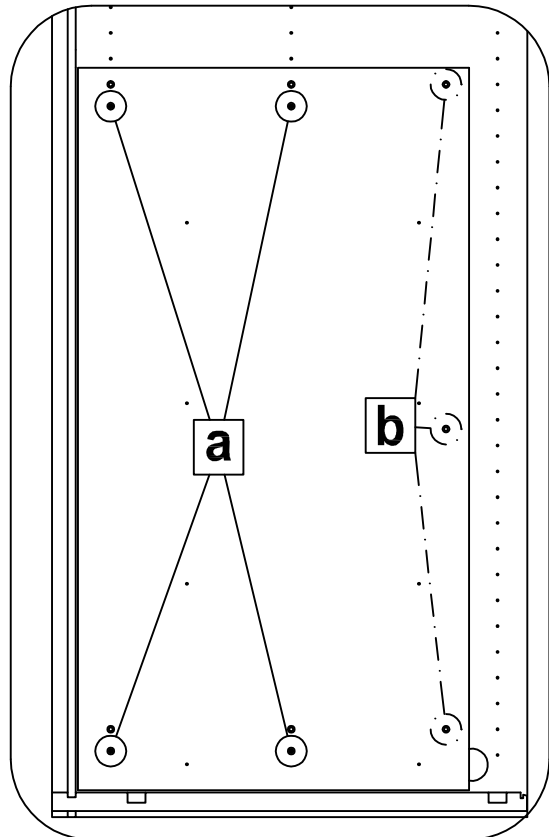

3

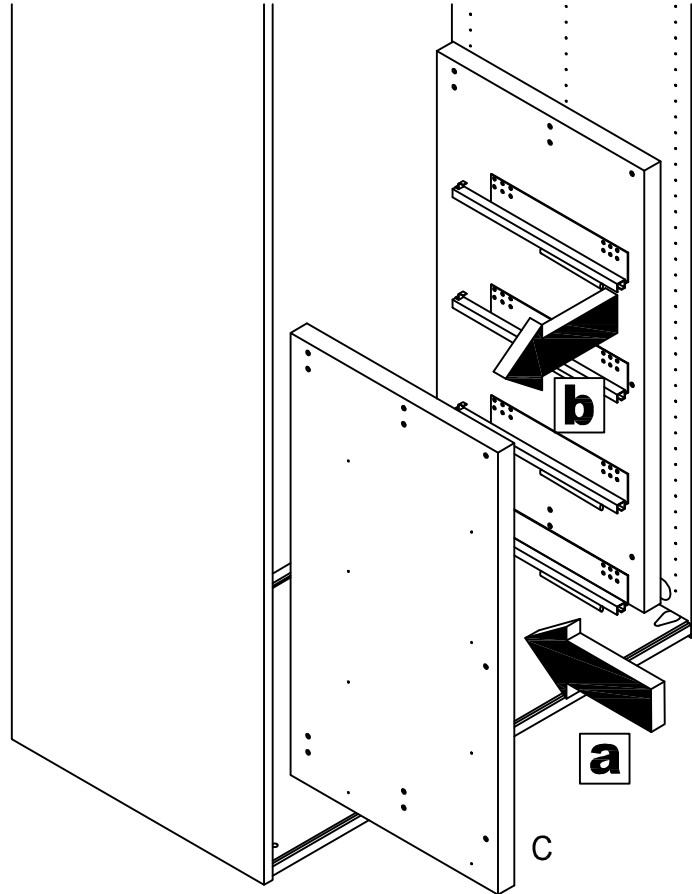

4

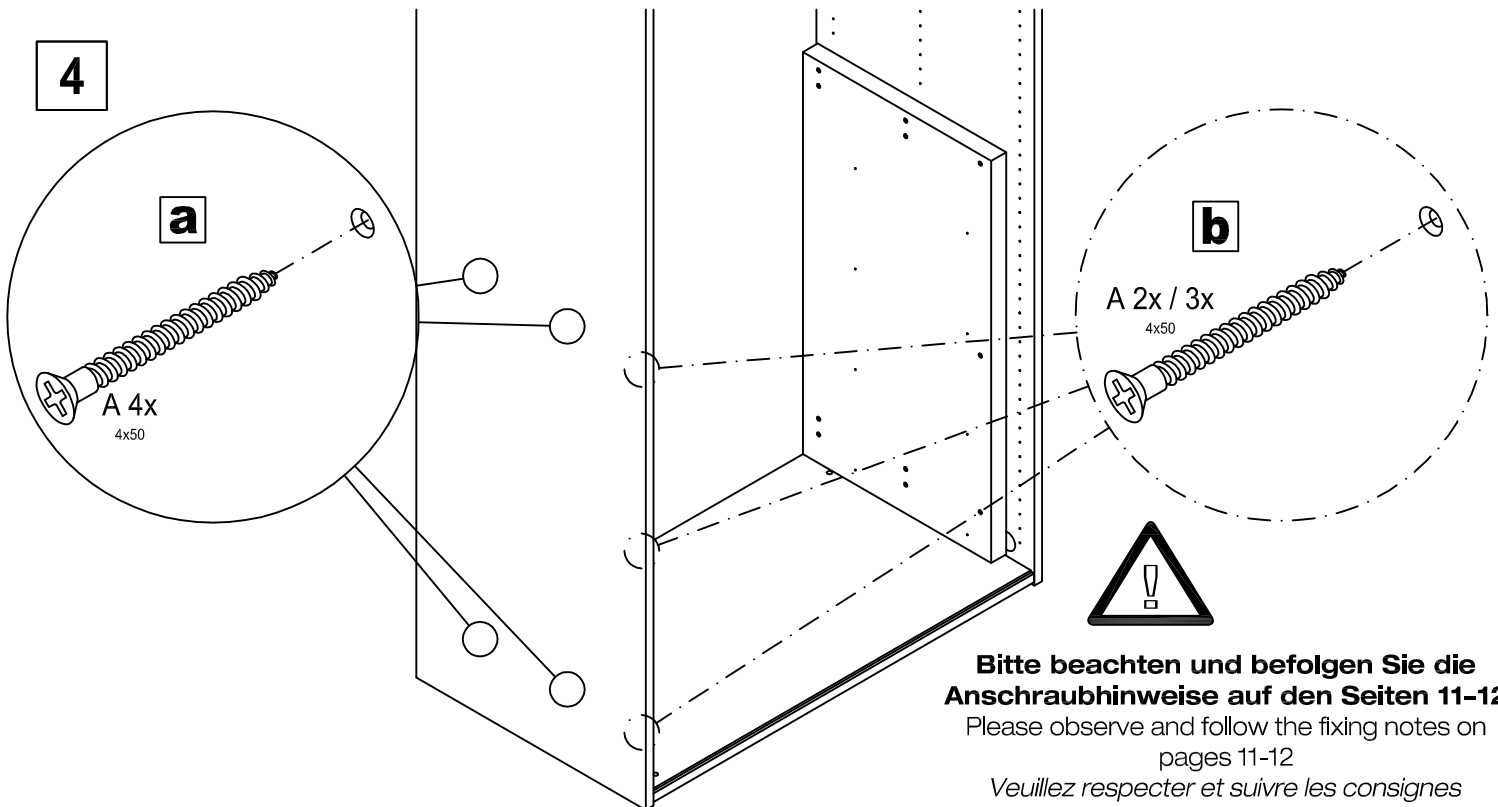

**Bitte beachten und befolgen Sie die Anschraubhinweise auf den Seiten 11-12**

Please observe and follow the fixing notes on pages 11-12

*Veuillez respecter et suivre les consignes d'assemblage des pages 11 à 12*

Let a.u.b. op de schroefaanwijzingen op de blz. 11-12

(5)

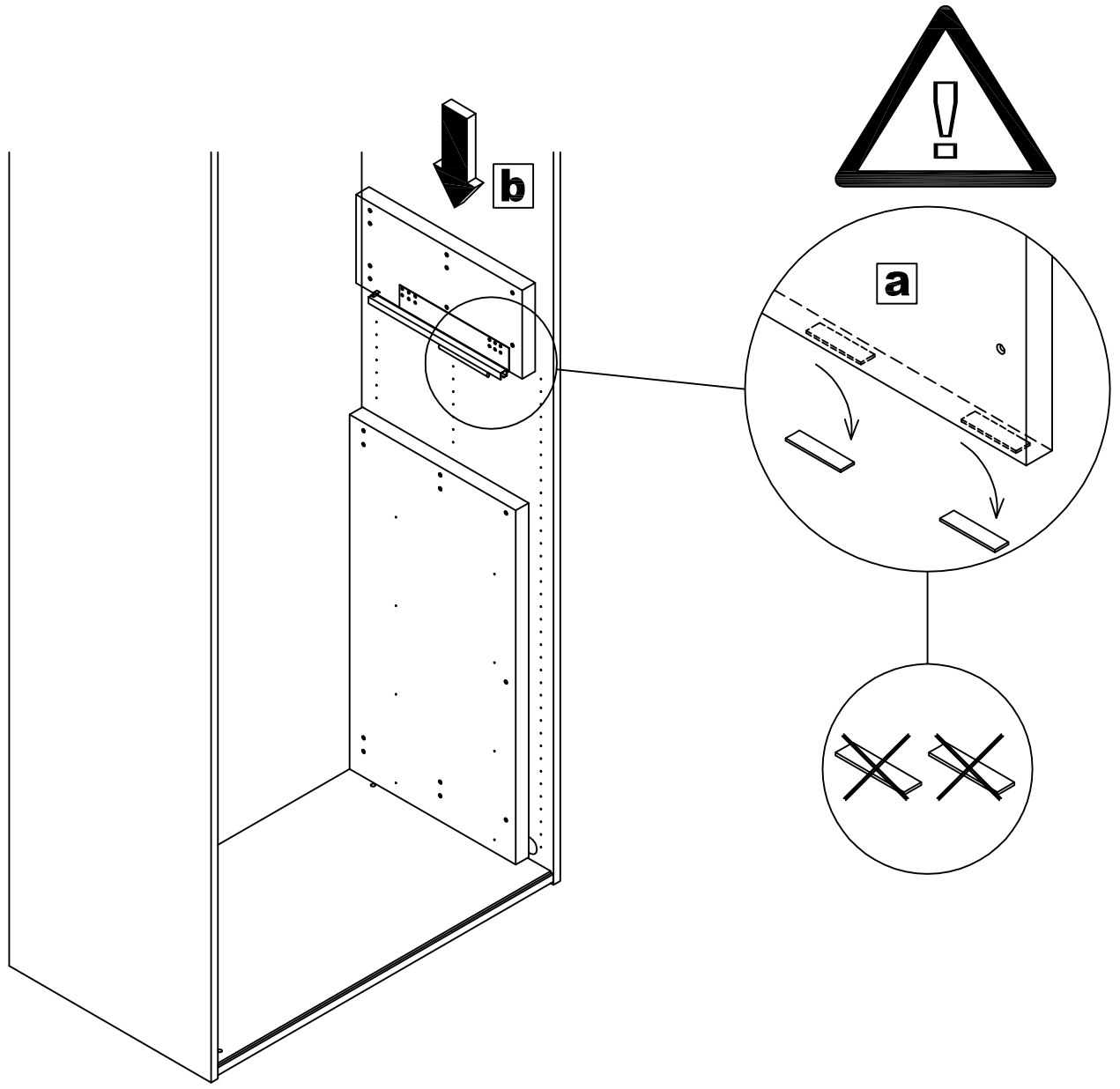

## Schubkastenmontage

Drawer assembly  
Montage des tiroirs  
Montage van de laden

D 1x / 2x

**50er Breite**  
50 cm width  
Largeur de 50 cm  
50 cm breedte

E 1x

**50er Breite**  
50 cm width  
Largeur de 50 cm  
50 cm breedte

F 1x / 2x / 3x / 4x

**50er Breite**  
50 cm width  
Largeur de 50 cm  
50 cm breedte

1x / 2x / 3x / 4x

**BB 2359**

Mat.-Nr.: 1557137

A



1x

1482905

B



1x

4x40

276031

C



1x

4x27

348984

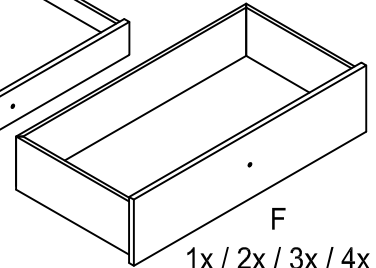
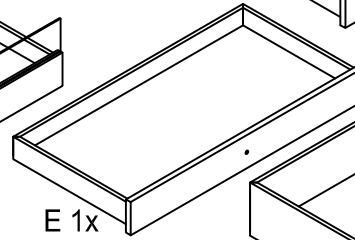
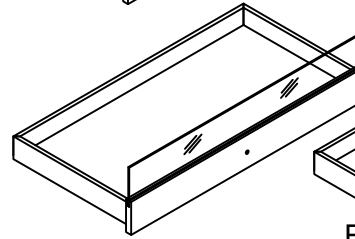
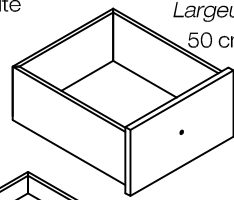
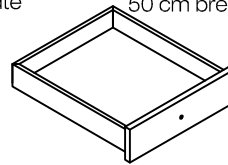
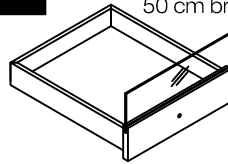

D 1x / 2x

**80 / 100er Breite**  
80 / 100 cm width  
Largeur de 80 / 100 cm  
80 / 100 cm breedte

E 1x

**80 / 100er Breite**  
80 / 100 cm width  
Largeur de 80 / 100 cm  
80 / 100 cm breedte

F

**1x / 2x / 3x / 4x**  
**80 / 100er Breite**  
80 / 100 cm width  
Largeur de 80 / 100 cm  
80 / 100 cm breedte

1

1x / 2x / 3x / 4x

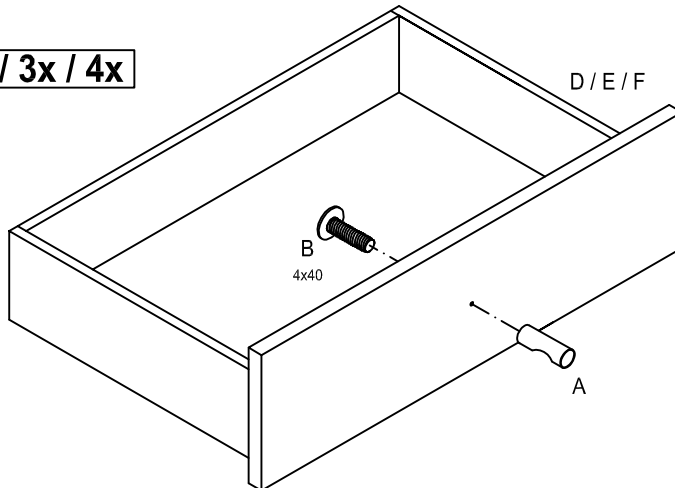

2

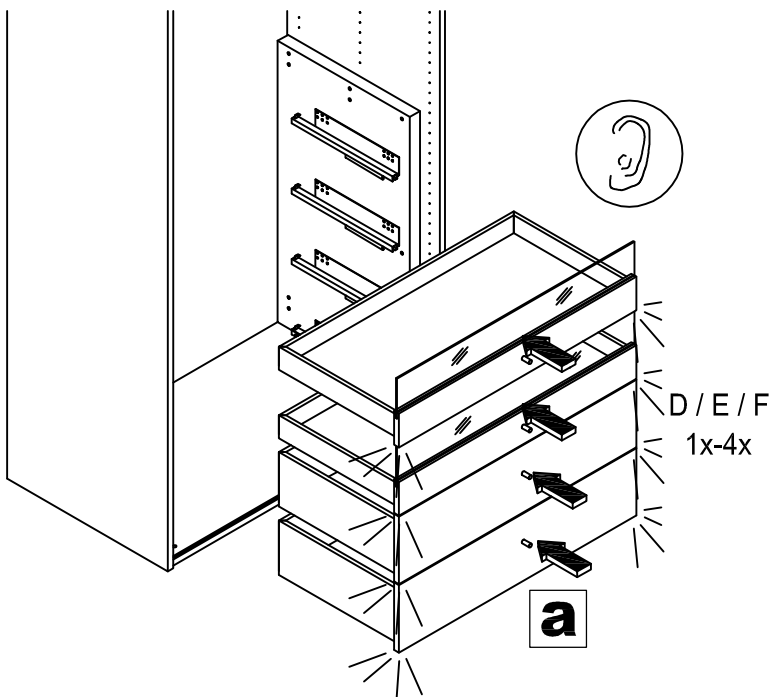

## Höhenverstellung Schubkasten

Height adjustment of drawers  
Réglage en hauteur des tiroirs  
Hoogteverstelling laden

b

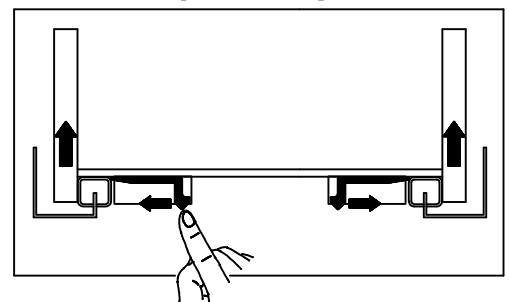

## Aushängen des Schubkastens

Detaching the drawer  
Dépose du tiroir  
Lade demonteren

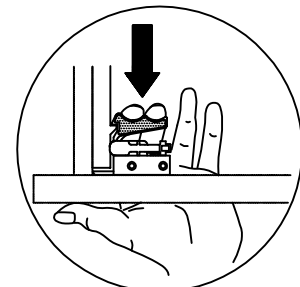

**Abdeckbodenmontage**  
Assembling cover shelf  
*Montage du plateau supérieur*  
Dekbladmontage

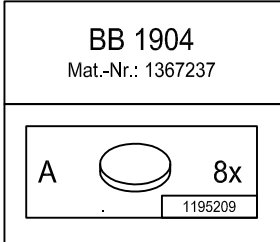

**B**  
**Breite = 48 cm**  
Width = 48 cm  
*Largeur = 48 cm*  
Breedte = 48 cm

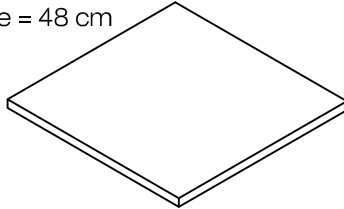

**B**  
**Breite = 78 / 98 cm**  
Width = 78 / 98 cm  
*Largeur = 78 / 98 cm*  
Breedte = 78 / 98 cm

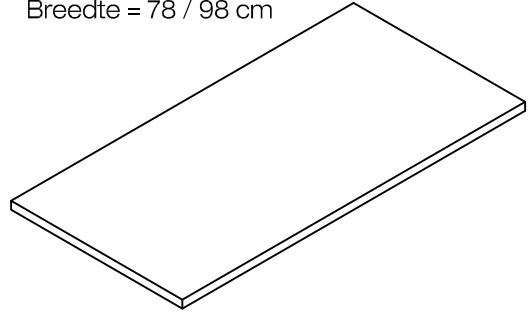

**1**

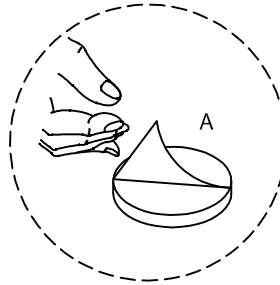
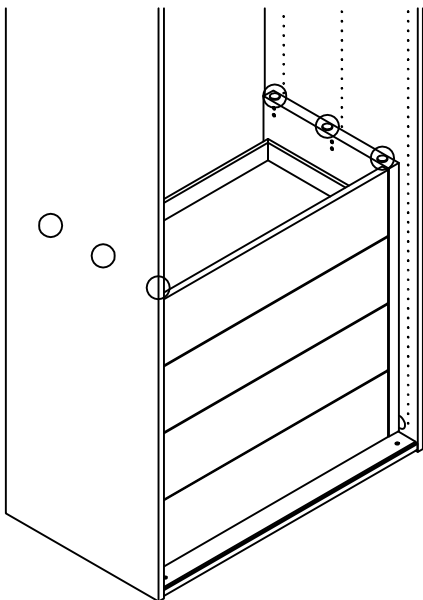

**a**

**Folie abziehen!**  
Take off foil!  
*Enlever le film de protection!*  
Folie verwijderen!

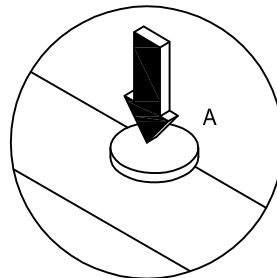

**b**

**c**

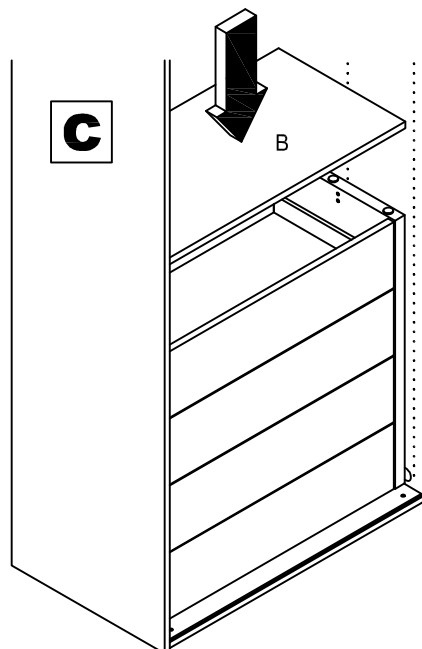



**LED-Lichtboden**

LED illuminated shelf  
Tablette lumineuse LED  
LED-lichtplank

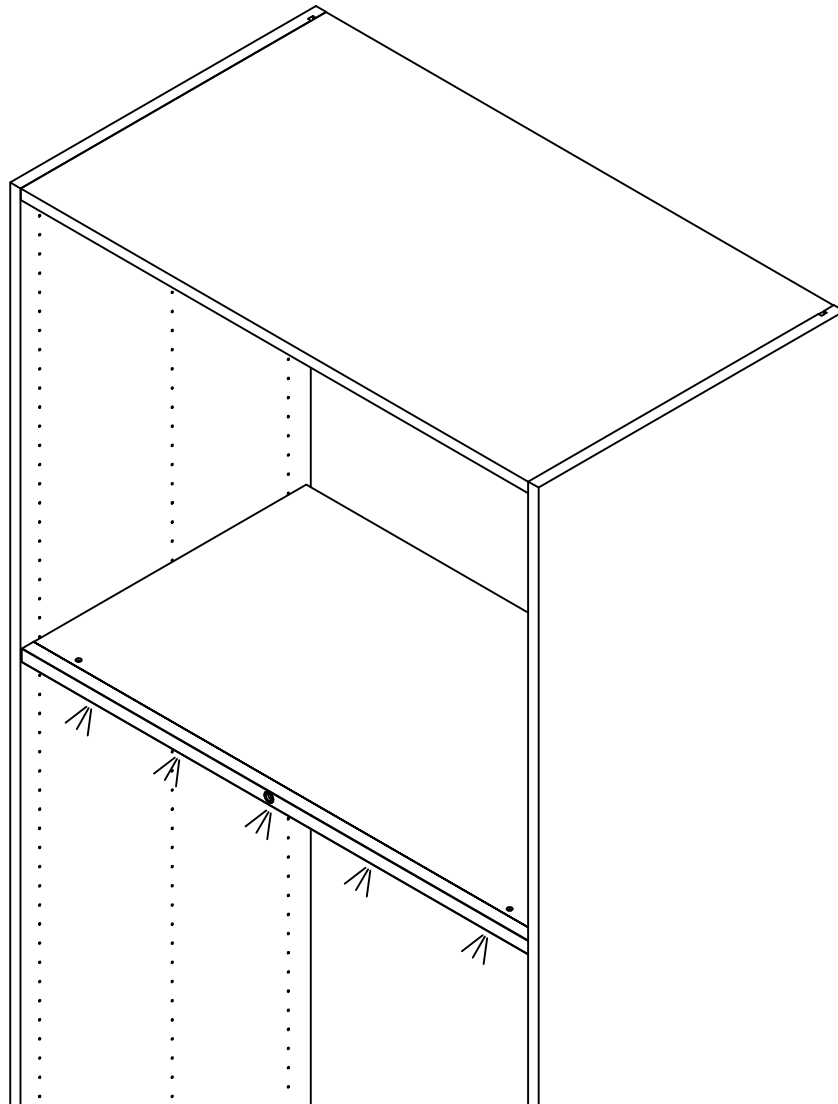

**Montage darf nur durch fachkundiges Personal erfolgen**

Fitting has to be done by qualified personnel

Le montage doit uniquement être effectué par de main d'oeuvre spécialisée

Montage uitsluitend door vakkundig personeel

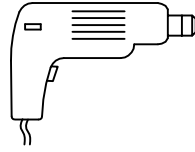
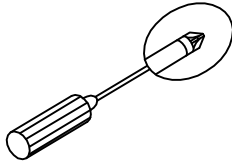
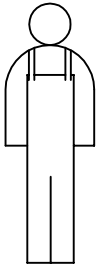

**BB 1848**

Mat.-Nr.: 1311110

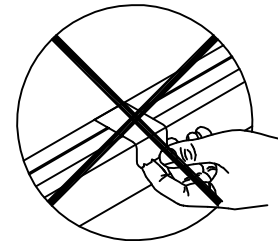
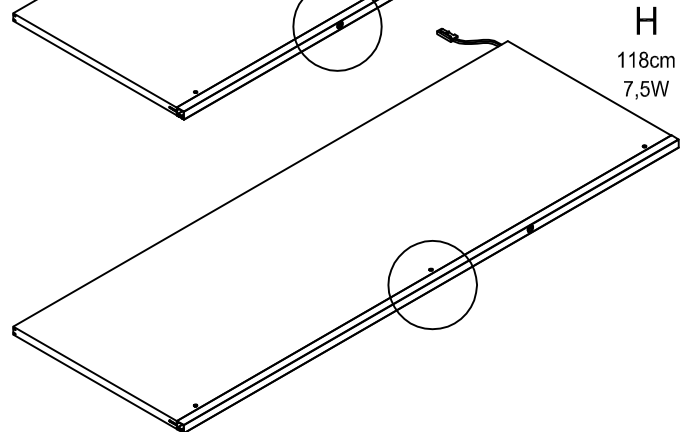
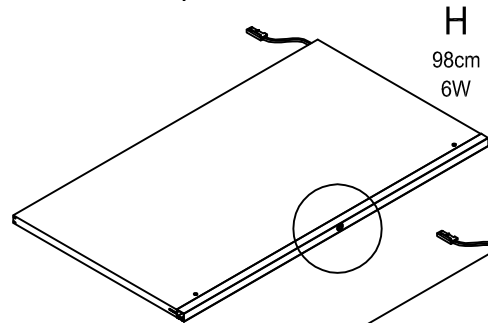
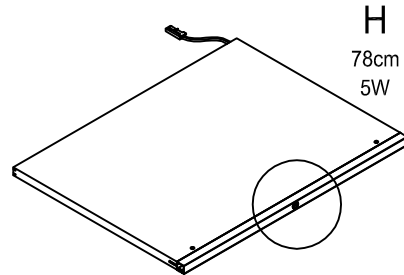
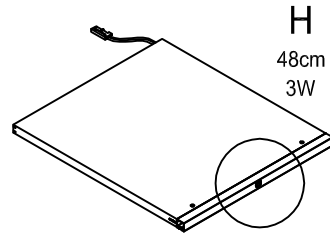
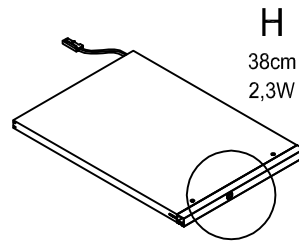
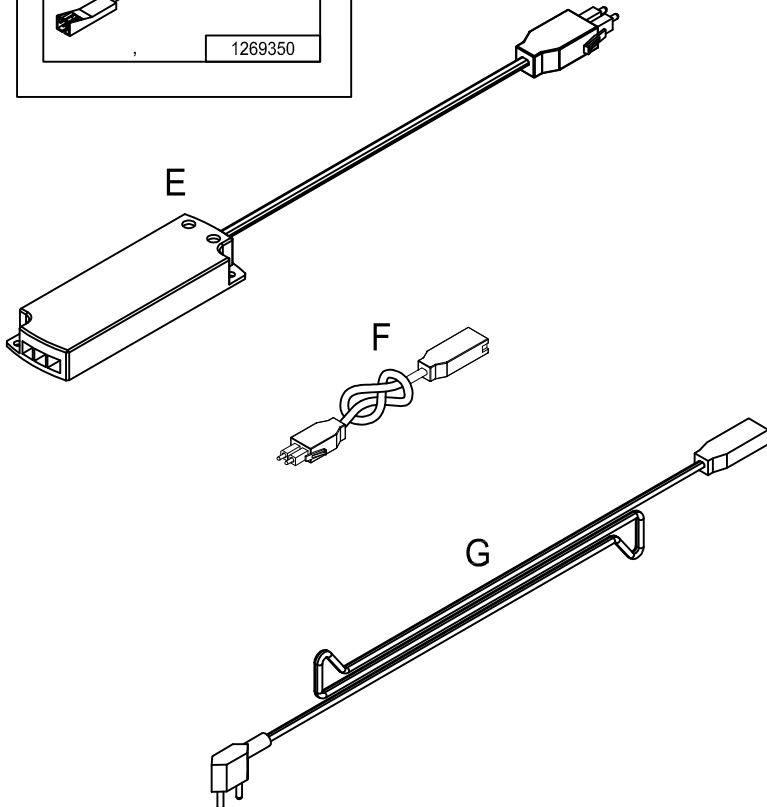
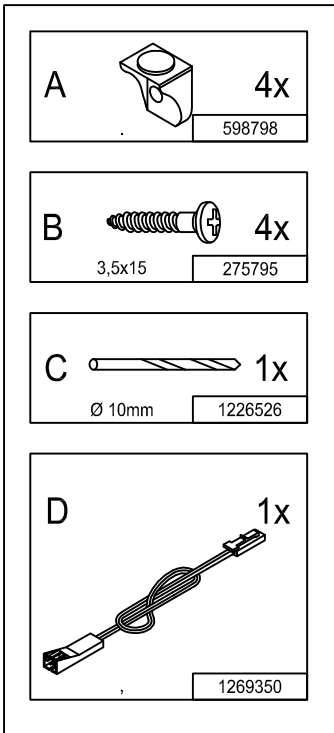

**Klebestreifen auf der Leuchte darf vor der Montage nicht entfernt werden!**

Adhesive strip on lamp must not be removed before assembly!

Le morceau de bande adhésive ne doit pas être retiré de la lampe avant le montage!

Plakband op de lamp mag vóór de montage niet worden verwijderd!

1

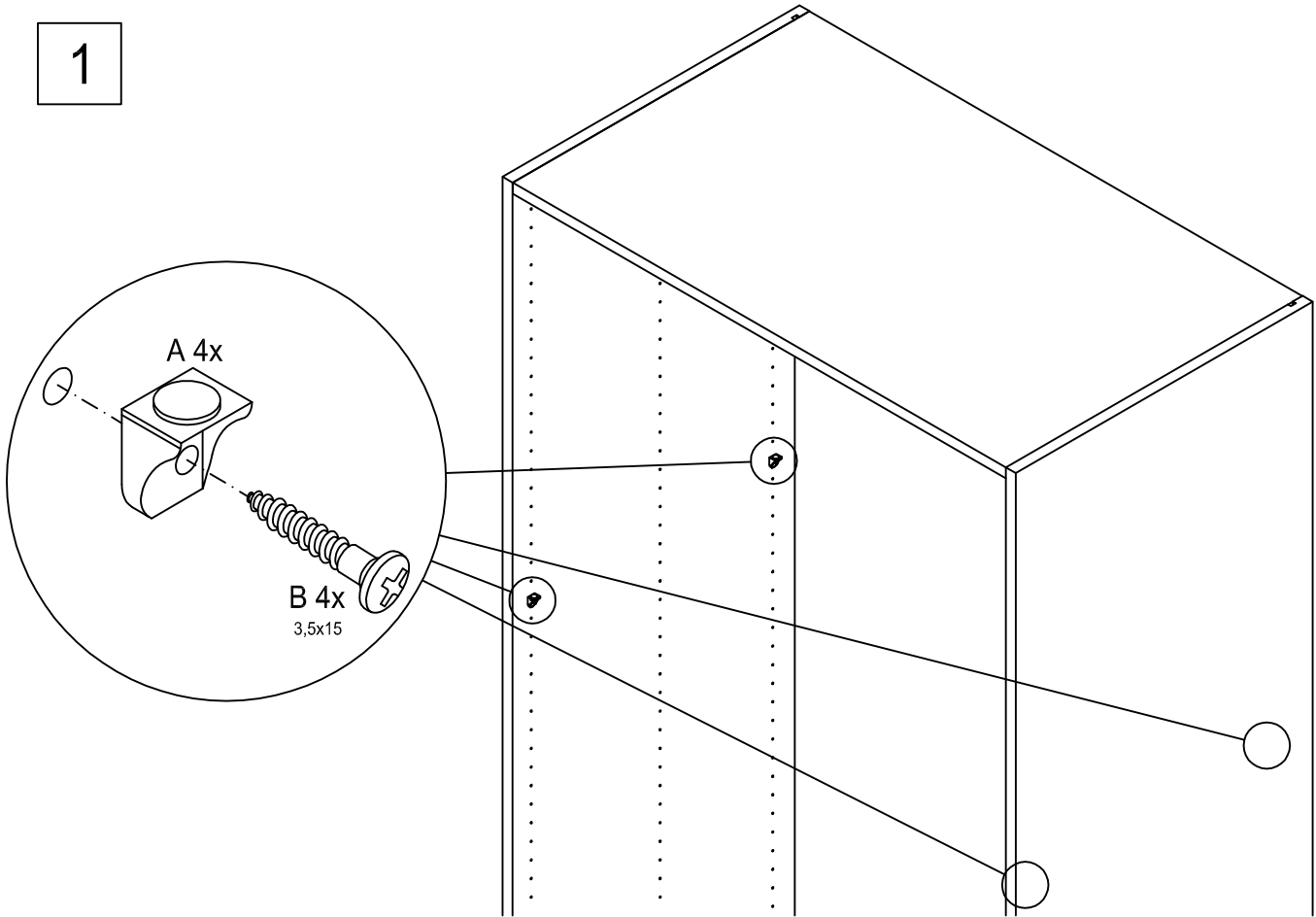

2

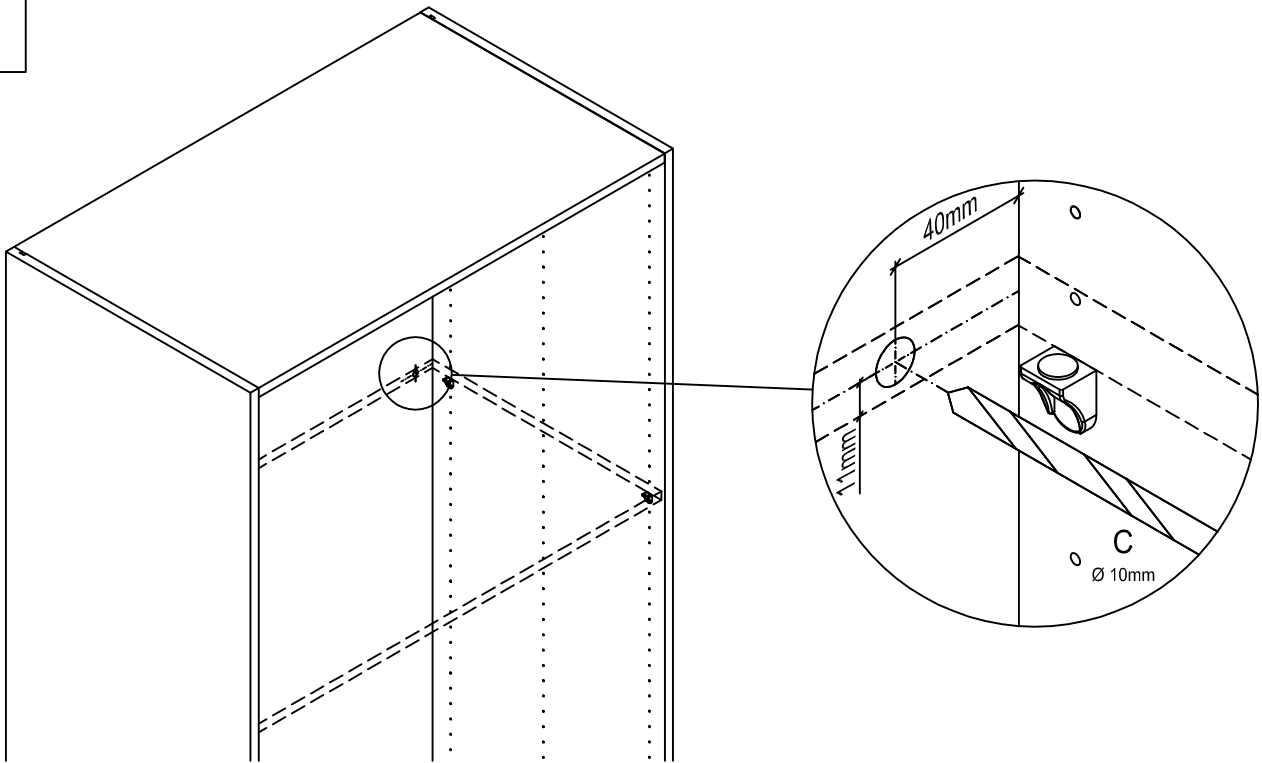

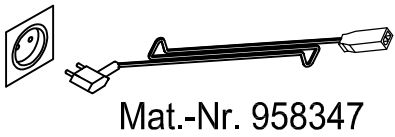
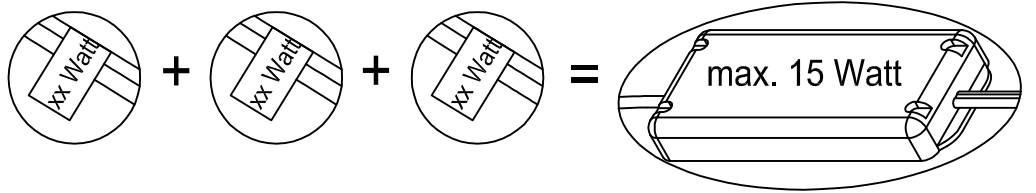
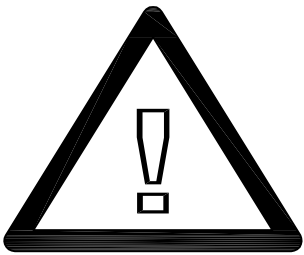
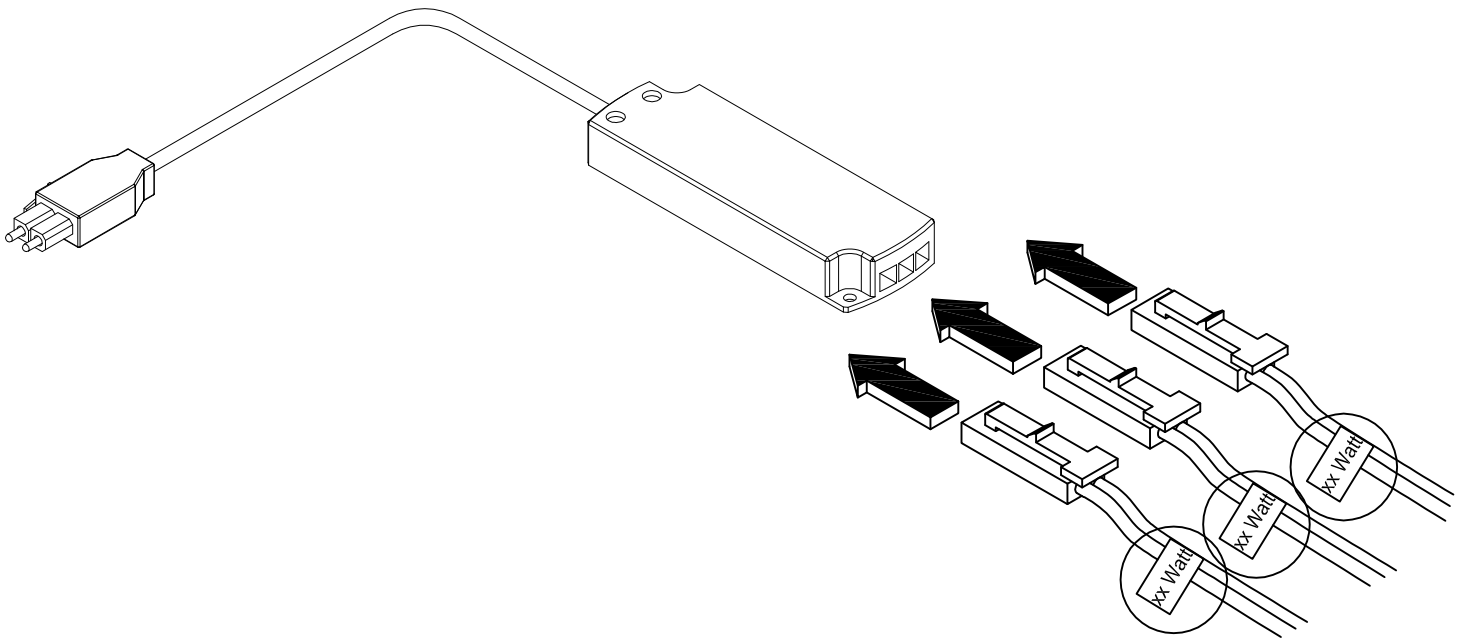

Mat.-Nr. 654319

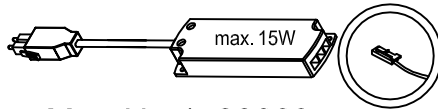

Mat.-Nr. 1590223

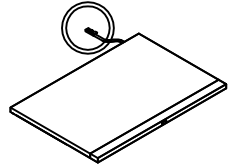

Mat.-Nr. 958347

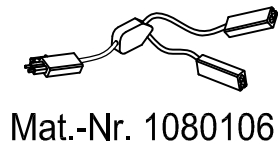

Mat.-Nr. 654319

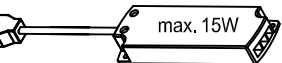
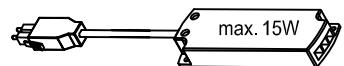

Mat.-Nr. 1590223

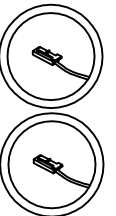

3

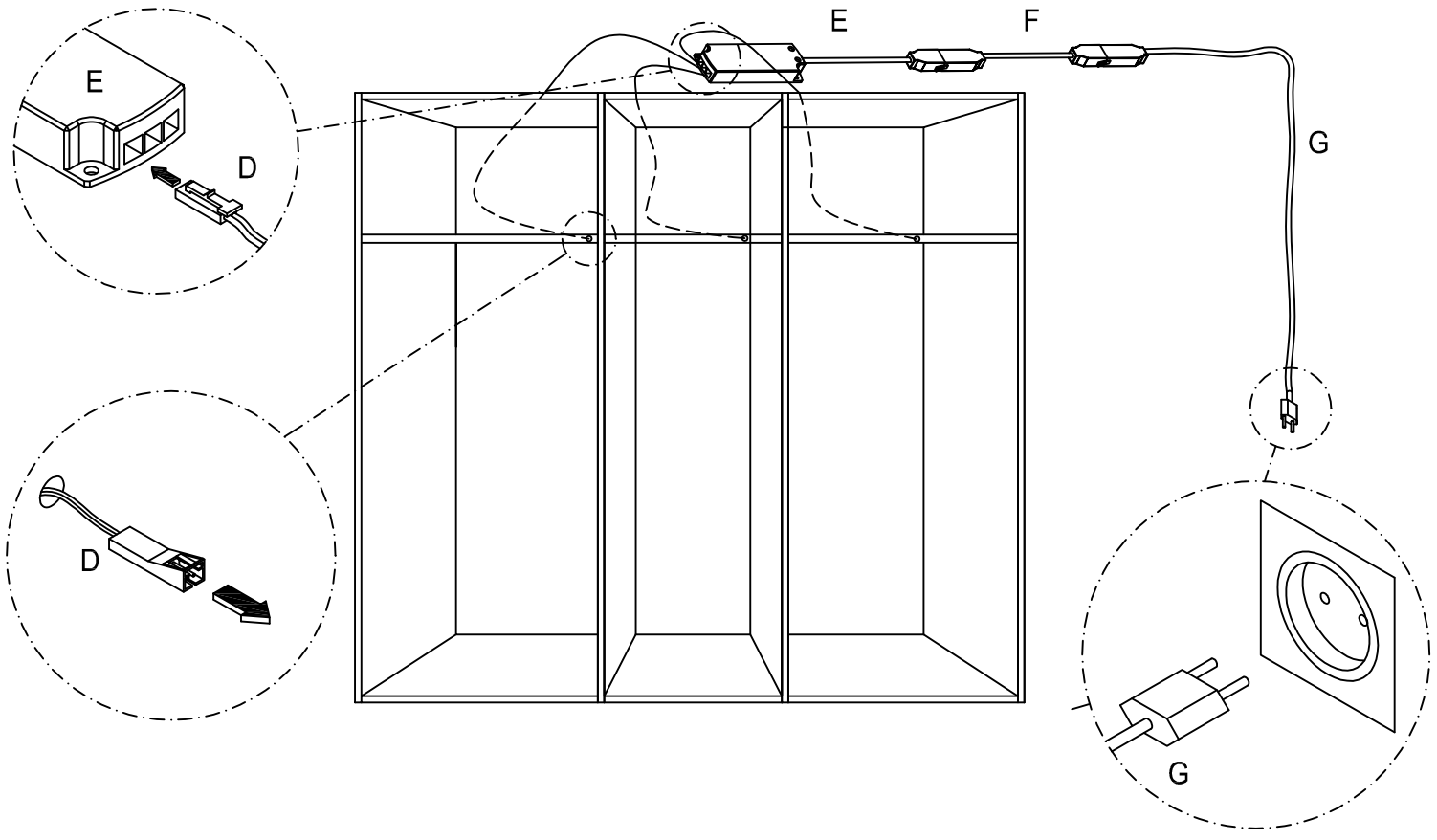

4

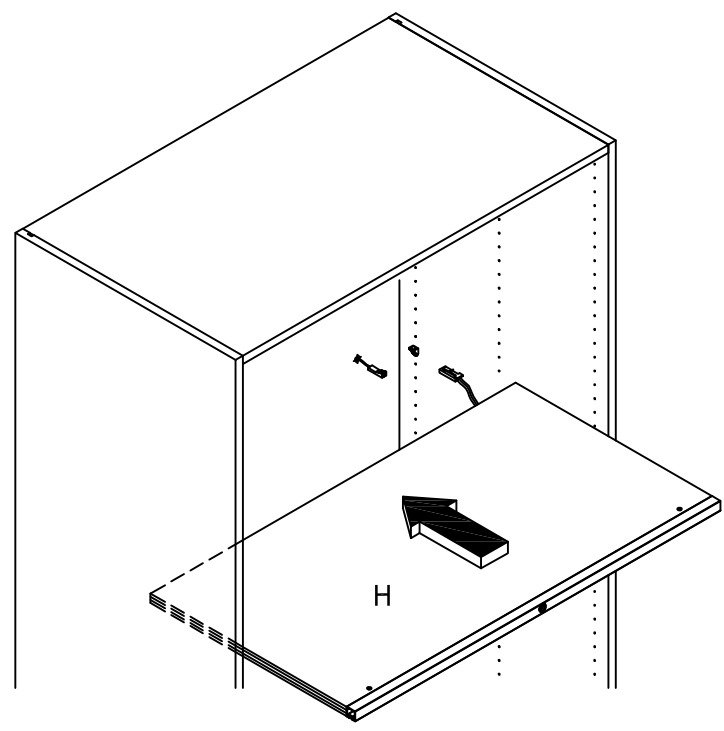

6

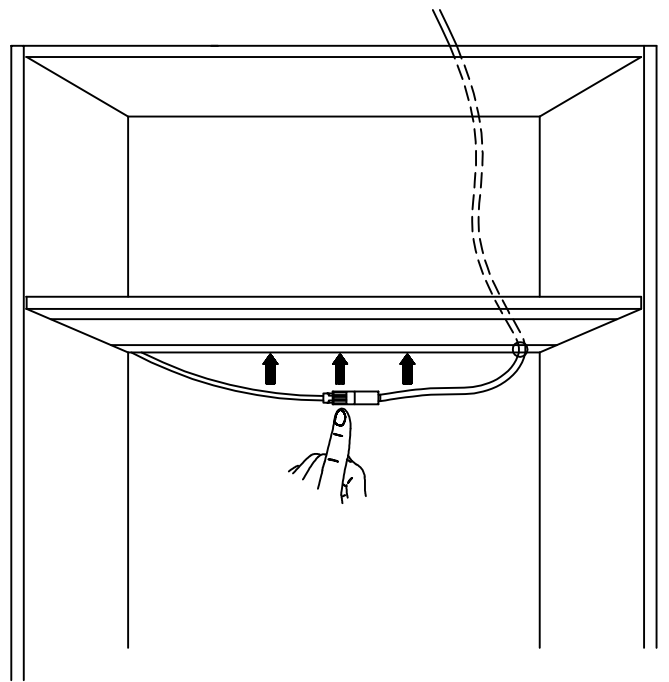
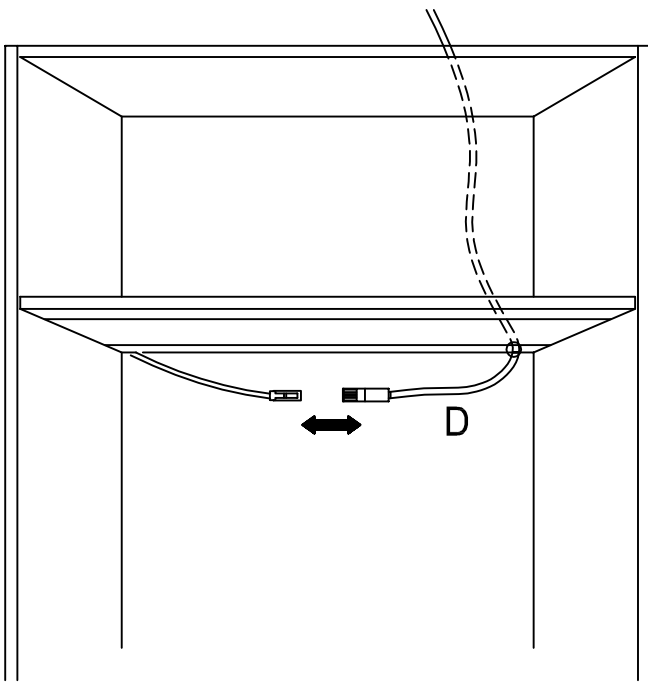

6

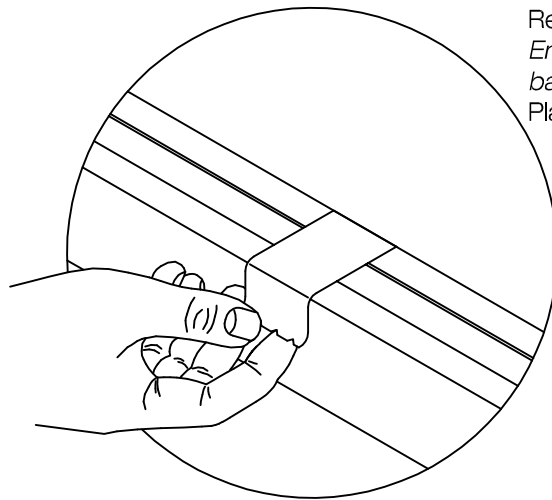
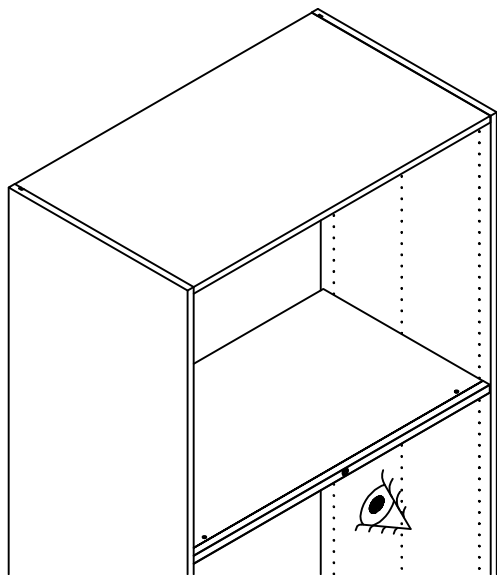

**Klebeband abziehen!**  
Remove adhesive band!  
*Enlevez le morceau de bande adhésive!*  
Plakband verwijderen!

# Krawattenhalter

Tie holder

Support cravates

Stropdassenhouder

## Montage darf nur durch fachkundiges Personal erfolgen

Fitting has to be done by qualified personnel

Le montage doit uniquement être effectué par de main d'oeuvre spécialisée

Montage uitsluitend door vakkundig personeel

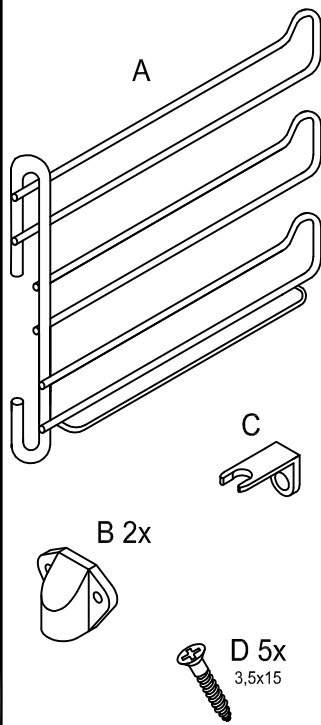
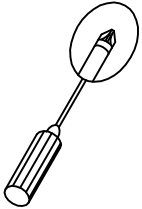
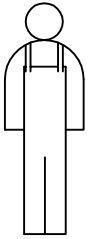

1

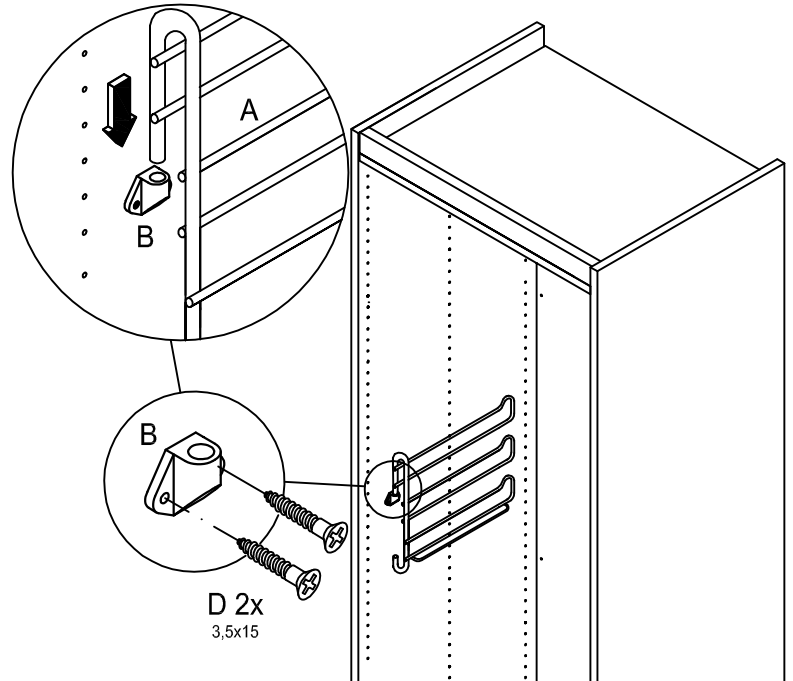

2

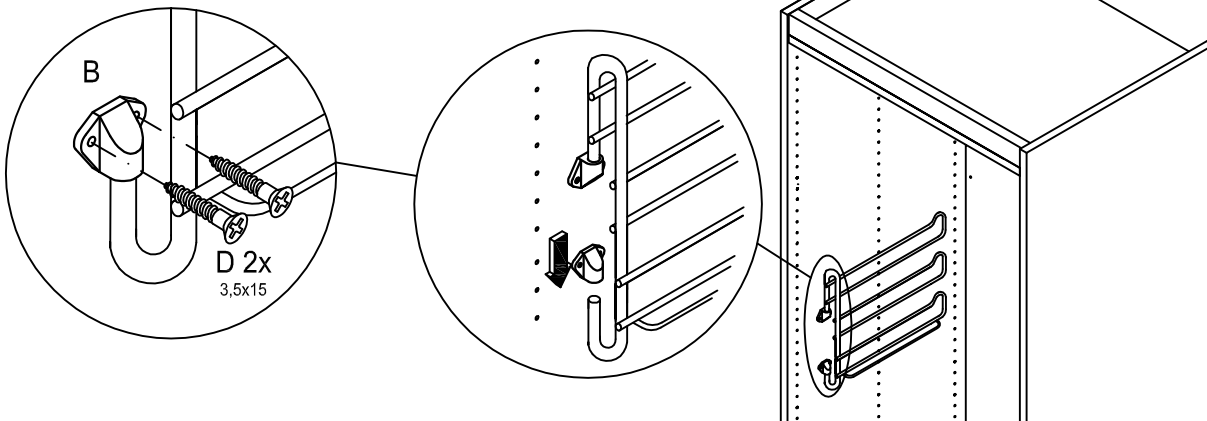

3

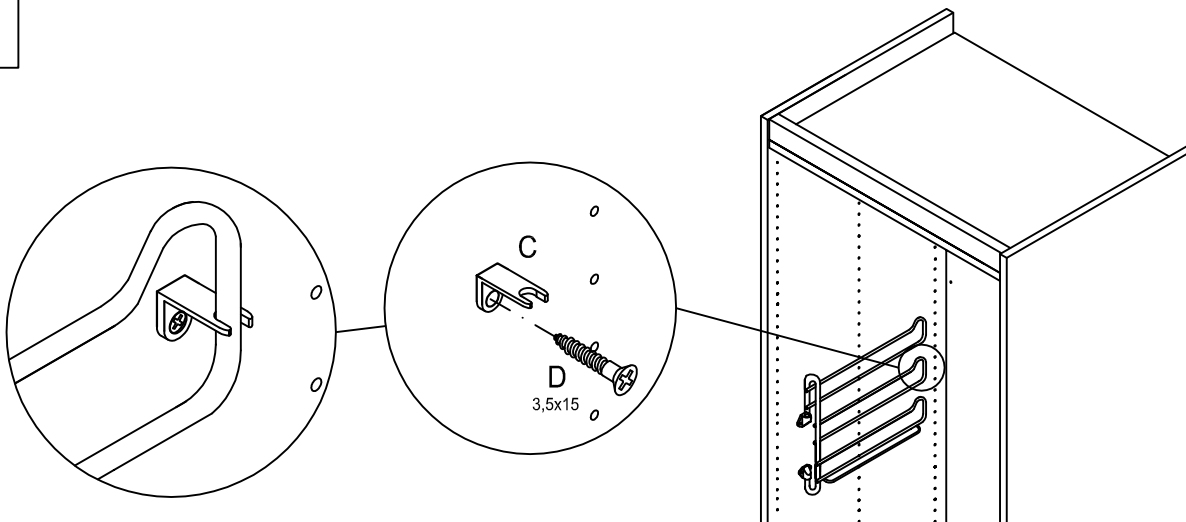

# MONTAGEANLEITUNG HOSENHALTER TYP 782099

TROUSER HOLDER  
SUPPORT PANTALONS  
PANTALONHOUDER

MONTAGE · ASSEMBLY · MONTAGE · MONTAGE

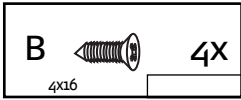
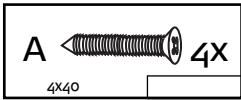

**Montage darf nur durch fachkundiges Personal erfolgen**

Fitting has to be done by qualified personnel  
*Le montage doit uniquement être effectué par de main d'oeuvre spécialisée*

Montage uitsluitend door vakkundig personeel

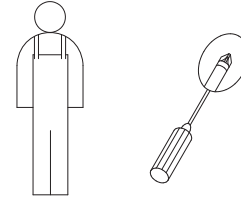

1

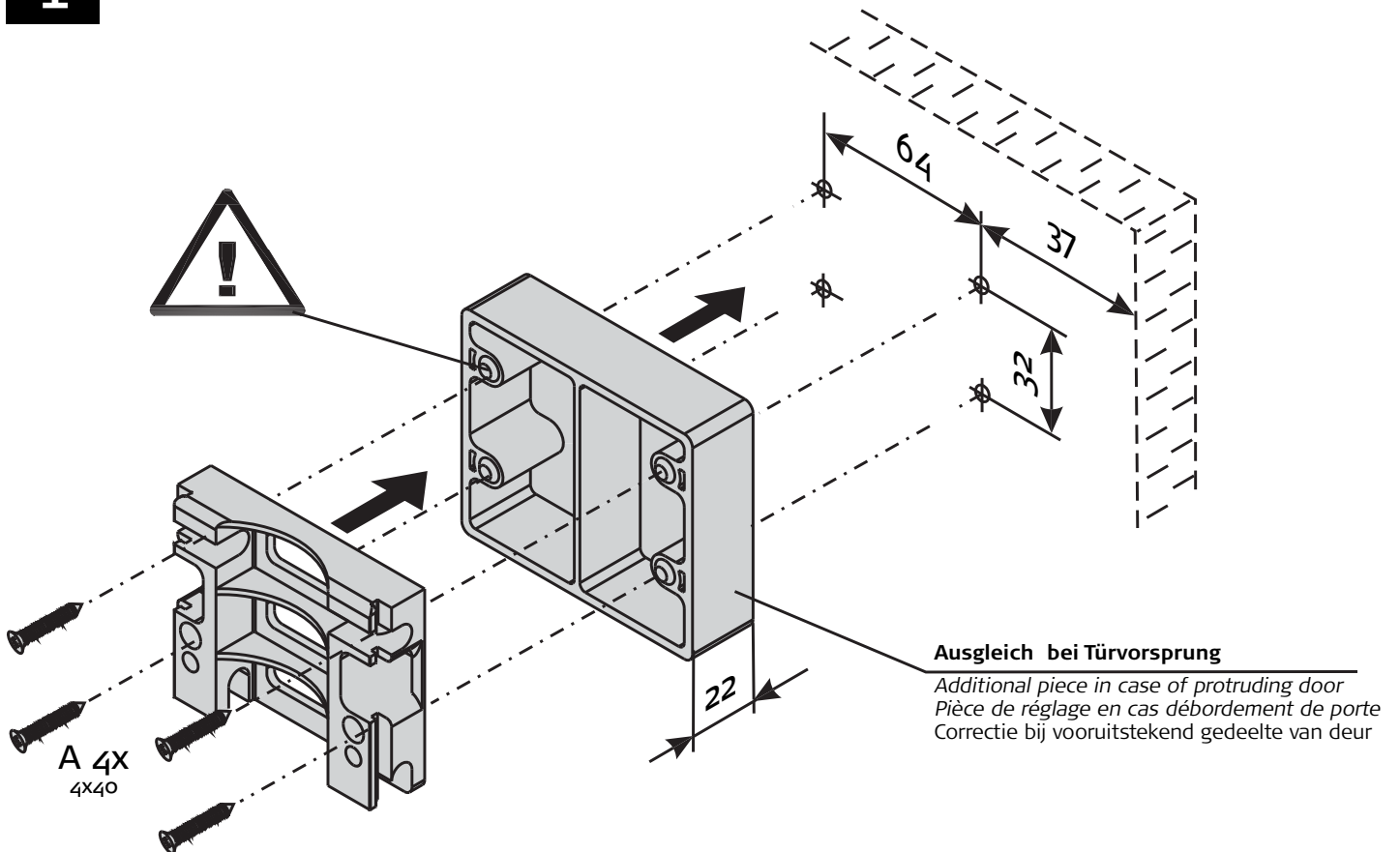



# MONTAGEANLEITUNG HOSENHALTER TYP 782099

TROUSER HOLDER  
SUPPORT PANTALONS  
PANTALONHOUDER

MONTAGE · ASSEMBLY · MONTAGE · MONTAGE

2

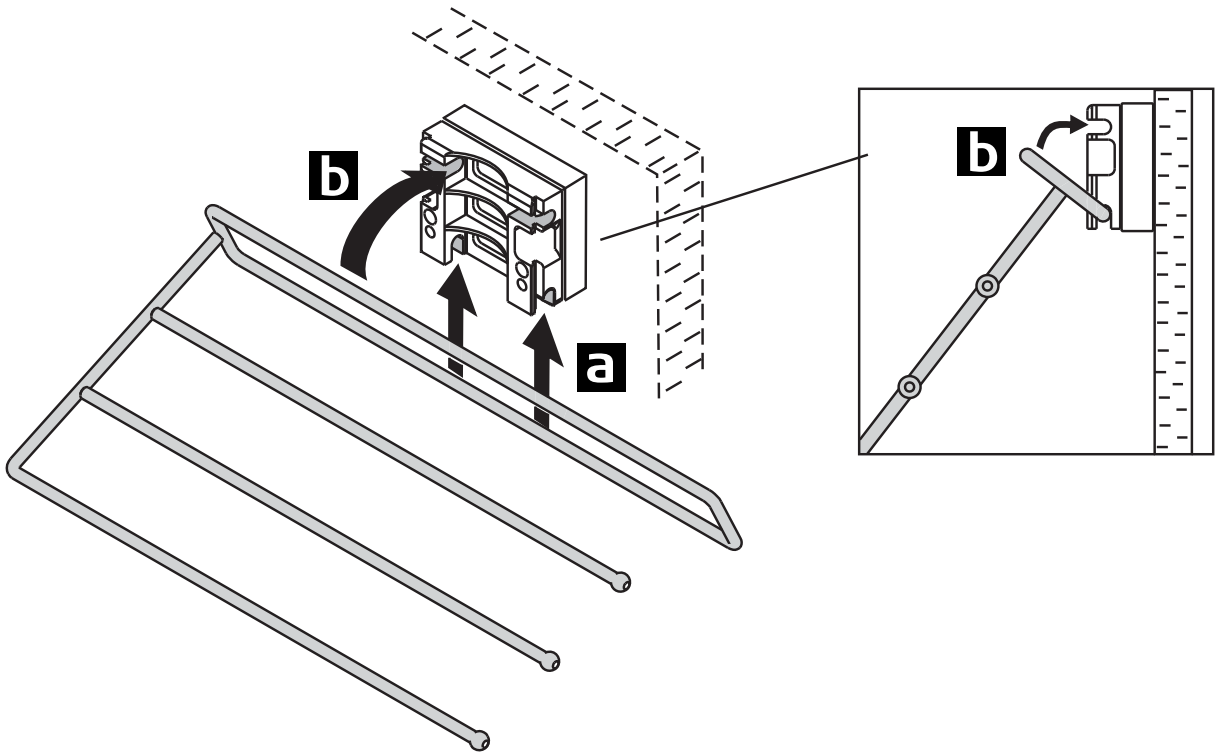

3

